



Mobile Accessory Valves

Catalog HY14-2405/US



Contents

Series and Description	Page
CFD	
Technical Information	1
Ordering Information	1
Dimensions	2
CFDA	
Technical Information	3
Ordering Information	3
Dimensions	4
DC25	
Technical Information	5
Ordering Information	6
Dimensions	6
DS12, DS75	
Technical Information	7
Ordering Information	7
Dimensions	8
DWV	
Technical Information	9
Ordering Information	9
Dimensions	10
DXV	
Technical Information	11
Ordering Information	11
Dimensions	12
HP	
Technical Information	13
Ordering Information	14
Dimensions	15
Performance Curve	15

Continued on next page

 **WARNING**

FAILURE OR IMPROPER SELECTION OR IMPROPER USE OF THE PRODUCTS AND/OR SYSTEMS DESCRIBED HEREIN OR RELATED ITEMS CAN CAUSE DEATH, PERSONAL INJURY AND PROPERTY DAMAGE.

This document and other information from Parker Hannifin Corporation, its subsidiaries and authorized distributors provide product and/or system options for further investigation by users having technical expertise. It is important that you analyze all aspects of your application and review the information concerning the product or system in the current product catalog. Due to the variety of operating conditions and applications for these products or systems, the user, through its own analysis and testing, is solely responsible for making the final selection of the products and systems and assuring that all performance, safety and warning requirements of the application are met.

The products described herein, including without limitation, product features, specifications, designs, availability and pricing, are subject to change by Parker Hannifin Corporation and its subsidiaries at any time without notice.

Offer of Sale

The items described in this document are hereby offered for sale by Parker Hannifin Corporation, its subsidiaries or its authorized distributors. This offer and its acceptance are governed by the provisions stated in the "Offer of Sale".

Contents

Series and Description	Page
LO	
Technical Information	16
Ordering Information	16
Dimensions	17
LOA	
Technical Information	18
Ordering Information	18
Dimensions	19
PD and PDC	
Technical Information	20
Ordering Information	20
Dimensions	21
RPJL	
Technical Information	22
Ordering Information	22
Dimensions	23
Performance Curve	22
RPL	
Technical Information	24
Ordering Information	24
Dimensions	25
Performance Curve	24
S, H, SM and HM	
Technical Information	26
Ordering Information	27
Dimensions	28 - 29
Performance Curves	30
WJL	
Technical Information	31
Ordering Information	31
Dimensions	32
Performance Curves	32
Offer of Sale	33

General Description

Series CFD flow controls are a constant volume, priority-type flow control designed for power steering.

Operation

Flow enters the valve through the inlet. The spool orifice size is fixed and determines flow from the controlled flow port. When controlled flow demand is satisfied, the balance of the inlet flow passes through the excess flow port and returns to the tank. The excess flow port is not a work port and must not be pressurized. In addition, flow cannot be reversed through the excess flow port.

Flow through the controlled port can be reversed, but it is not pressure compensated.

Features

- Fixed flow rate
- Cross drilled spool provides extremely accurate metering
- Hardened metering spool
- High tensile, cast iron body

Specifications

Input Flow	56.25 LPM (15 GPM)
Operating Pressure SAE Ports NPTF Ports	177 Bar (2500 PSI) 138 Bar (2000 PSI)
Minimum Compensation Pressure	3.45 Bar (50 PSI)
Operating Temperature Range (Ambient)	Nitrile Seals: -40°C to +93°C (-40°F to +200°F)
Material	Body – High strength cast iron
Filtration	ISO Code 16/13 SAE Class 4 or better
Mounting Position	In-line; no restrictions

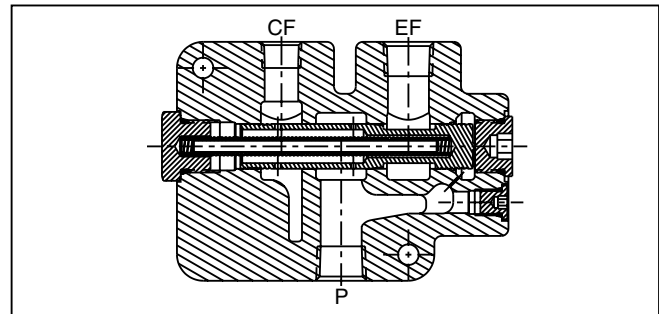
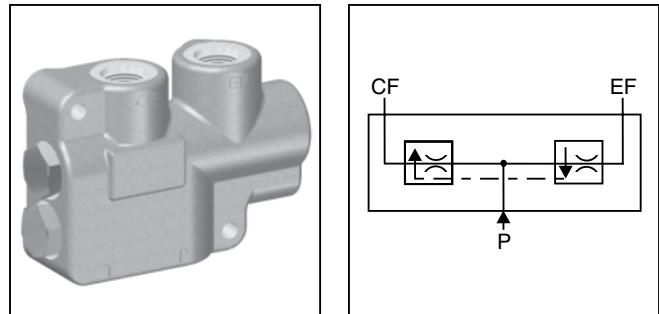

Ordering Information

CFD — Port Size — Controlled Flow

Constant Volume Priority Flow Control

Code	CF Port	EF Port	P Port	T Port
10	SAE-8	SAE-10	SAE-10	3/8" NPTF
50	3/8" NPTF	1/2" NPTF	1/2" NPTF	3/8" NPTF
75	1/2" NPTF	3/4" NPTF	3/4" NPTF	3/8" NPTF

Code	Description
1	3.75 LPM (1.0 GPM)
1.5	5.63 LPM (1.5 GPM)
2	7.5 LPM (2 GPM)
3	11.25 LPM (3 GPM)
4	15 LPM (4 GPM)
5	18.75 LPM (5 GPM)

Service Parts

SAE - 10 plug	10HP50V-S
SAE - 4 plug	4HP50V-S
Spool Seal	3910N-7

Note: The body and the internal parts are non-service items.

Inch equivalents for millimeter dimensions are shown in (**)

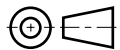
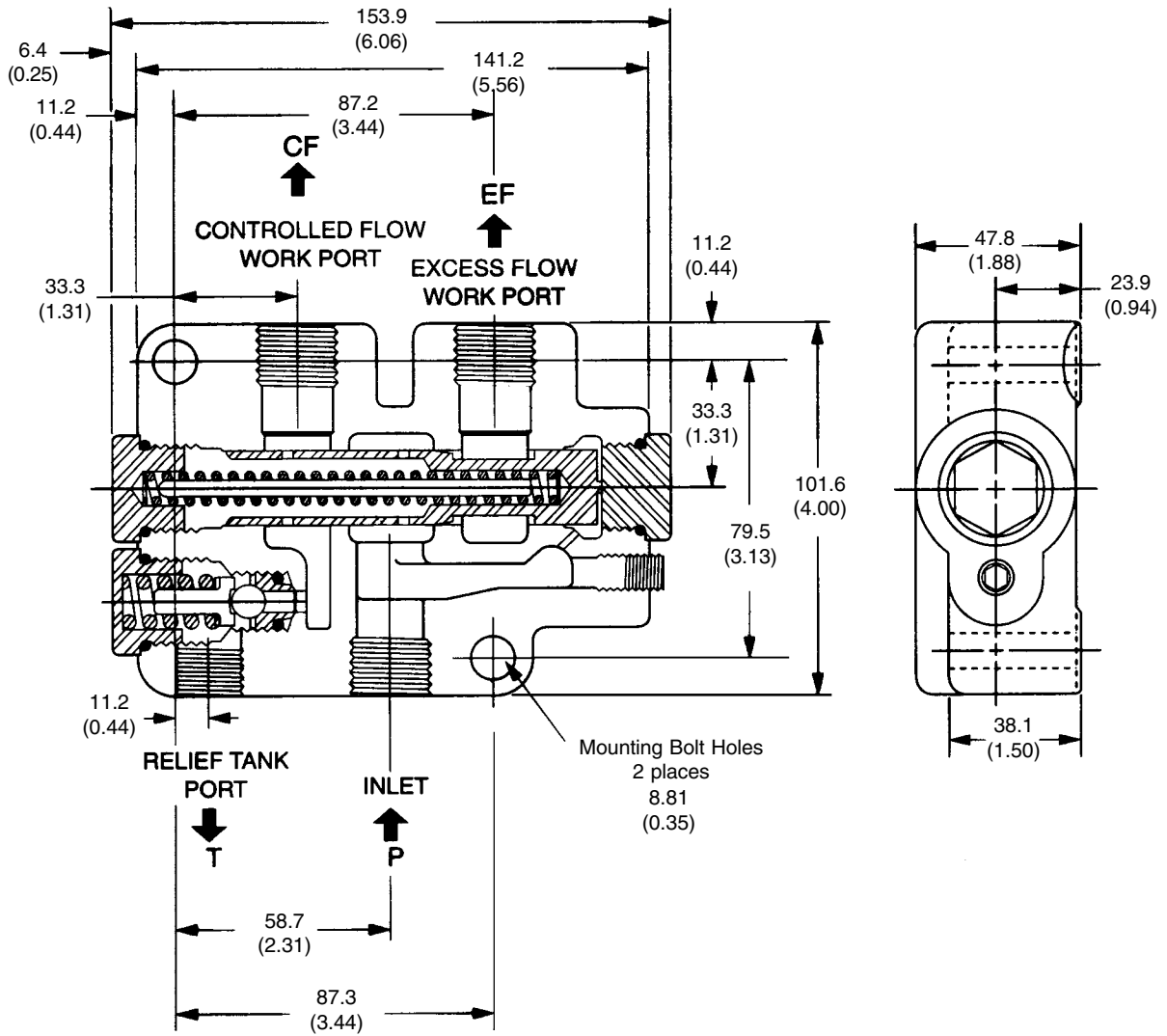

General Description

Series CFDA flow controls offer a dependable means of obtaining flow adjustment up to 56.25 LPM (15 GPM). It provides easy manual control where frequent flow change is required. Pressure compensation provides a smooth, constant output flow regardless of pressure changes at the controlled flow port.

Operation

Flow enters the valve through the inlet. Rotating the adjusting knob varies the flow from the controlled flow port. When controlled flow demand is satisfied, the balance of the inlet flow passes through the excess flow port and returns to the tank. The excess flow port is not a work port and must not be pressurized.

Flow through the controlled port can be reversed, but is not pressure compensated.

Features

- Adjustable flow rate
- Cross drilled spool provides extremely accurate metering
- Hardened metering spool
- High tensile, cast iron body

Specifications

Input Flow	56.25 LPM (15 GPM)
Operating Pressure SAE Ports NPTF Ports	177 Bar (2500 PSI) 138 Bar (2000 PSI)
Flow Adjustment Range	6 turns of knob from minimum to maximum flow
Operating Temperature Range (Ambient)	Nitrile Seals: -40°C to +93°C (-40°F to +200°F)
Material	Body – High strength cast iron
Filtration	ISO Code 16/13 SAE Class 4 or better
Mounting Position	In-line; no restrictions

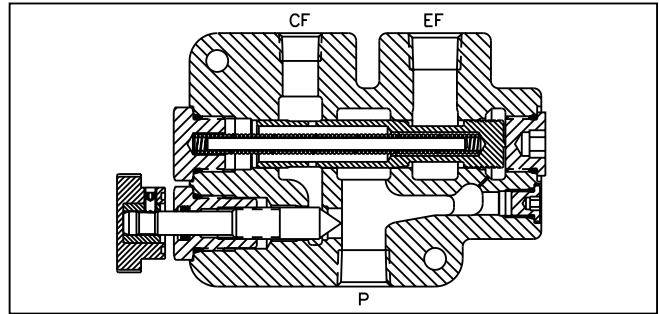
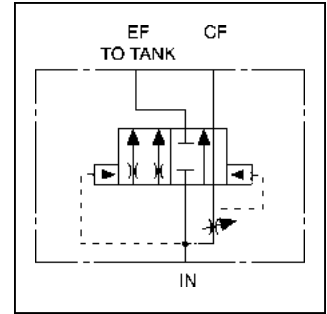
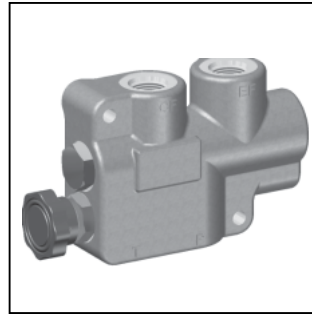

Ordering Information

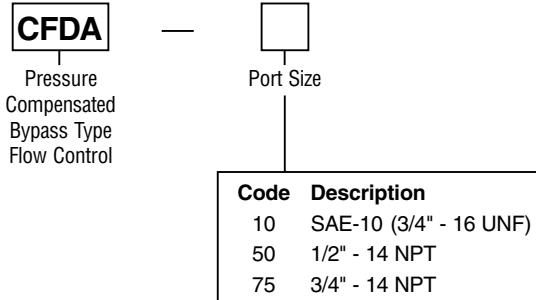

Service Parts

Knob	03236001
Seal Knob Cap	3910N-7

Note: The body and the internal parts are non-service items.

General Description

Series DC25 accessory valves are priority flow controls. They are designed for applications where two separate hydraulic circuits are to be served from a single pump. The valve provides a priority flow to the primary (CF) circuit, and an excess flow to a secondary (EF) circuit or to the tank. When the excess flow port is plugged, the valve will function as a restrictive-type, pressure compensated flow control.

Features

- Excess flow can be used in a secondary circuit
- Hardened metering spool

Specifications

Input Flow	112.5 LPM (30 GPM)
Adjustable Controlled Flow Range	3.75-97.5 LPM (1-26 GPM)
Accuracy of Adjustment	± 10% @ 11.25 LPM (3 GPM) or greater
Operating Pressure	SAE Ports 210 Bar (3000 PSI)
	NPTF Ports 138 Bar (2000 PSI)
Minimum Operating Pressure	4.8 Bar (70 PSI)
Operating Temperature Range (Ambient)	Nitrile Seals: -40°C to +93°C (-40°F to +200°F)
Material	Body – High strength cast iron Spool – Hardened and ground steel
Filtration	ISO Code 16/13, SAE Class 4 or better
Mounting Position	In-line; no restrictions
Knob Rotation	360° full adjustment

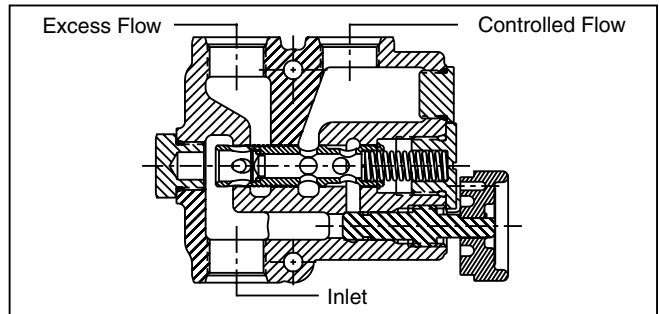
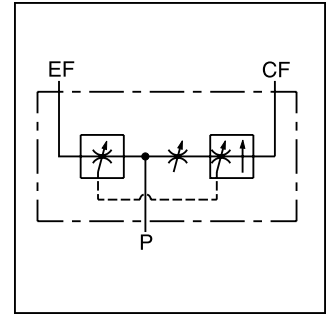
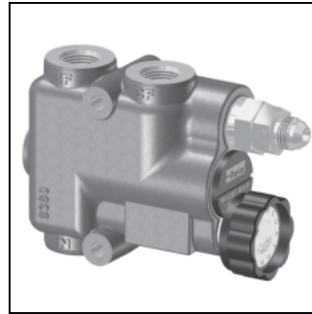

Operation

Flow enters the inlet port and passes through an adjustable control orifice. The control orifice can be varied externally in the adjustable version.

Flow through the adjustable control orifice causes a pressure drop which is sensed across the compensator spool. Excess flow across the compensator spool increases the pressure drop across it. This changes the pressure drop and shifts the spool allowing it to maintain priority flow and diverting more flow to the excess flow port. When pressure in the excess flow port exceeds the pressure in the controlled flow port, the spool will also shift to maintain the required priority flow to the primary circuit.

If the controlled flow port is blocked, the compensator spool will return to the closed position, allowing no flow through the valve.

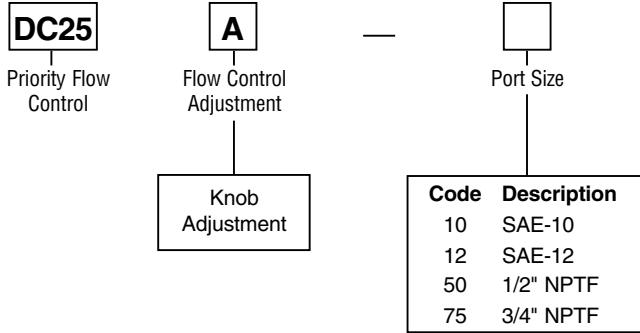

Service Parts

Relief Valve Kits	
34 to 86 Bar (500 to 1250 PSI)	20089001
121 to 138 Bar (1750 to 2000 PSI)	20089004
138 to 179 Bar (2000 to 2600 PSI)	20089005 (SAE ported valves only)
179 to 207 Bar (2600 to 3000 PSI)	20089006 (SAE ported valves only)
Knob Kit	00712017

Note: The body and the spool are not service items.

Dimensions

Inch equivalents for millimeter dimensions are shown in (**)

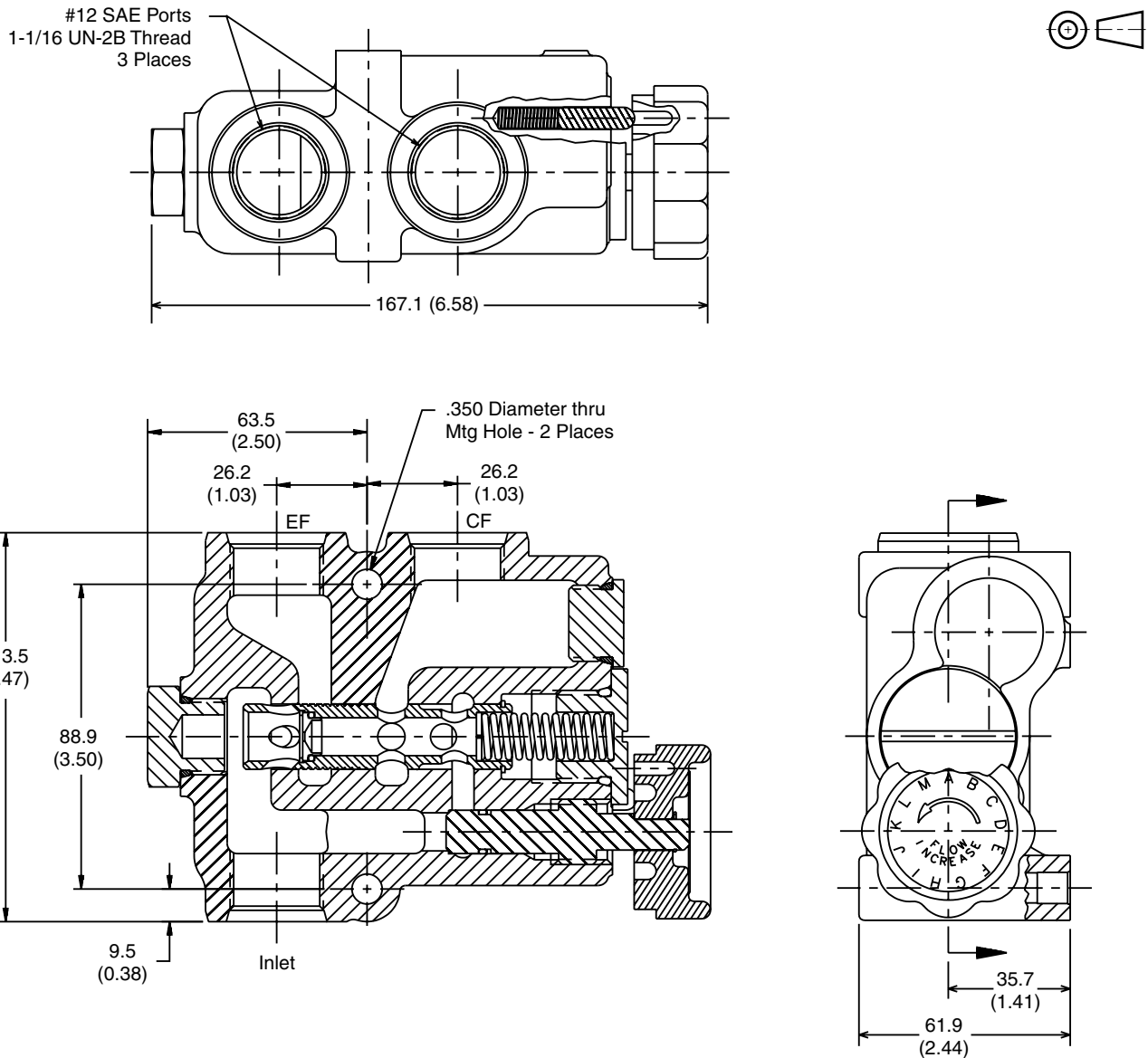

General Description

Series DS12 and DS75 accessory valves are two-position, double selector valves. They are designed for directing flow from one single hydraulic circuit to two separate hydraulic lines. This permits operation of two, double-acting cylinders with:

- one four-way control valve, or
- four single-acting cylinders with two three-way control valves.

The valve should be operated (shifted) prior to applying pressure to it. When the spool begins to move, all ports are momentarily connected.

Operation

In the normal mode, pump flow can enter the valve through either A or B port. The other port then becomes the return port. Port A is connected to Port D; Port B is connected to Port C. When the lever is pushed in, Port A is connected to Port E; Port B is connected to Port F.

Features

- Chrome plated spool
- High-tensile cast iron body

Specifications

Input Flow	93.75 LPM (25 GPM)
Operating Pressure SAE Ports NPTF Ports	207 Bar (3000 PSI) 138 Bar (2000 PSI)
Operating Temperature Range (Ambient)	Nitrile Seals: -40°C to +93°C (-40°F to +200°F)
Material	Body – High strength cast iron Spool – Hardened and ground steel
Filtration	ISO Code 16/13 SAE Class 4 or better
Mounting Position	In-line; no restrictions

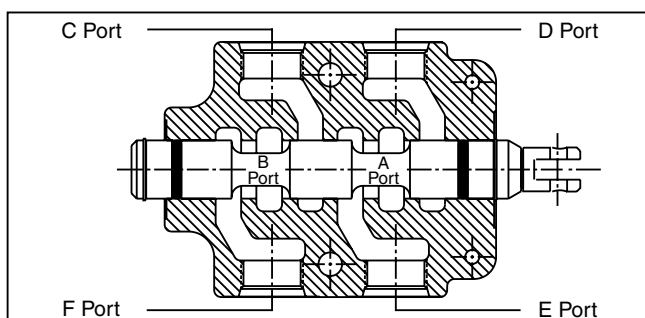
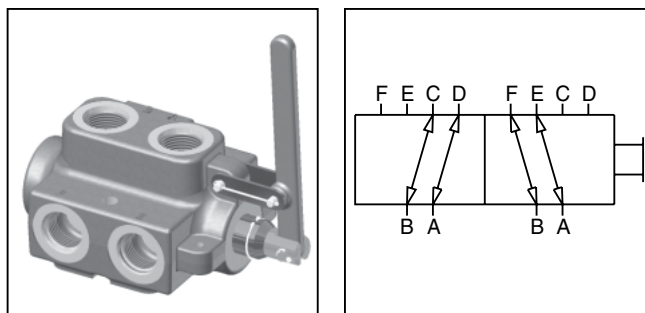

Ordering Information

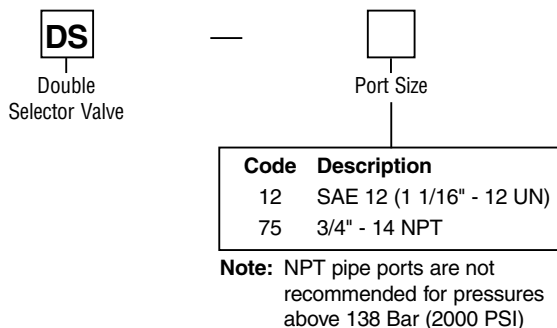

Service Parts

Handle Kit	06656001
Kit – Spool Seals and Retaining Rings	06492001
Clevis and Lock Washer Kit	08650235

Note: The body and the spool are not service items.

Dimensions

**Mobile Accessory Valves
Series DS**

Inch equivalents for millimeter dimensions are shown in (**)

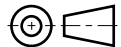
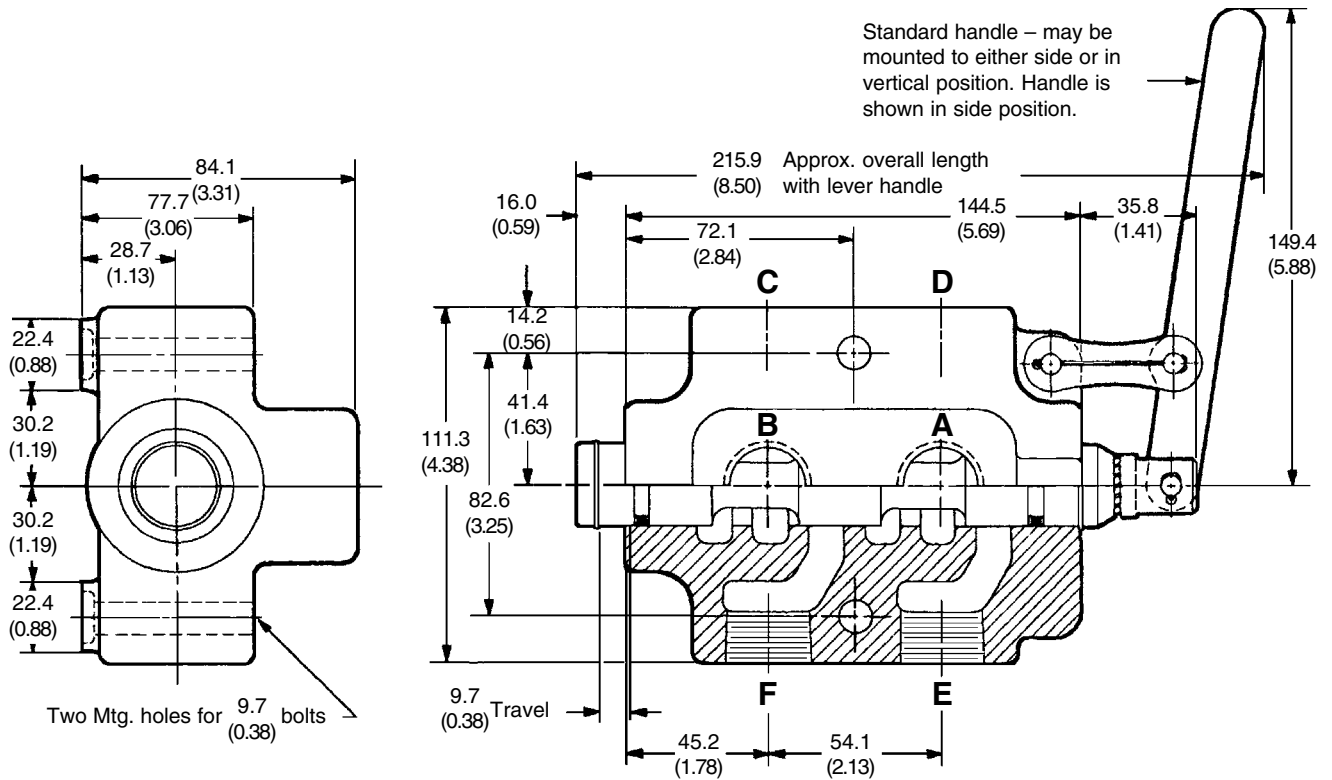

General Description

Series DWV relief valves are differential area, cross-over reliefs (cushion valves). They are designed to eliminate or minimize shock, surge, or overload conditions on hydraulic equipment. They may be used with cylinders of equal displacement, or with motors to provide crossover relief when the motors are stopped.

Operation

The DWV relief valve relieves oil from one side of the actuator to tank, therefore reducing shock and preventing overload. It also eliminates cavitation and the need for a separate tank connection. The valve should be installed as close to the actuator as possible for best results.

Features

- Compact, low profile design
- Fast response to cushion shocks and protect actuators
- Cartridge style relief valves
- High tensile, compacted graphite body

Specifications

Input Flow	93.75 LPM (25 GPM)
Operating Pressure SAE Ports NPTF Ports	210 Bar (3000 PSI) 138 Bar (2000 PSI)
Operating Temperature Range (Ambient)	Nitrile Seals: -40°C to +93°C (-40°F to +200°F)
Material	Body – High strength cast iron Poppet – Hardened and ground steel
Filtration	ISO Code 16/13 SAE Class 4 or better
Mounting Position	In-line; no restrictions

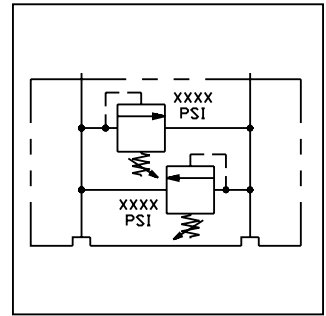
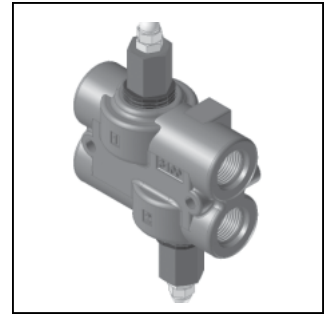
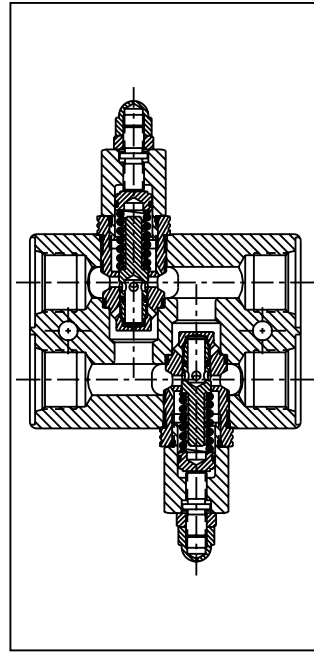

Ordering Information

DWV	□	□	□
Differential Area Crossover Relief	Port Size	Adjustment Option	Pressure Range

Code	Description
8	SAE-8 (3/4" - 16 UNF)
10	SAE-10 (7/8" - 14 UNF)
12	SAE-12 (1 1/16" - 12 UNF)
50	1/2" - 14 NPT
75	3/4" - 14 NPT

Code	Description
Omit	Shim Adjustable
A	Screw Adjustable

Code	Setting	Range
1250	89 Bar (1250 PSI)	35 - 89 Bar (500 - 1250 PSI)
2000	142 Bar (2000 PSI)	89 - 142 Bar (1250 - 2000 PSI)
2500	177 Bar (2500 PSI)	142 - 177 Bar (2000 - 2500 PSI)
3000	210 Bar (3000 PSI)	142 - 210 Bar (2000 - 3000 PSI)

Service Parts

Relief Valve Cartridges	
35 - 89 Bar (500 - 1250 PSI)	WHA-1250
89 - 142 Bar (1250 - 2000 PSI)	WHA-2000
142 - 177 Bar (2000 - 2500 PSI)	WHA-2500
177 - 210 Bar (2500 - 3000 PSI)	WHA-3000
O-Ring Seal Kit	00712359
Relief Adjustments	
Screw Adjustment – 1/4 turn = 200 PSI ±10%	
Shim Adjustment – 100 PSI	00462001
150 - 250 PSI	00459001
250 - 450 PSI	00458001

Note: The body and the internal parts of the relief valve (including the spring) are non-service items.

Performance Curves

Low End – 34 to 207 Bar (500 to 3000 PSI)

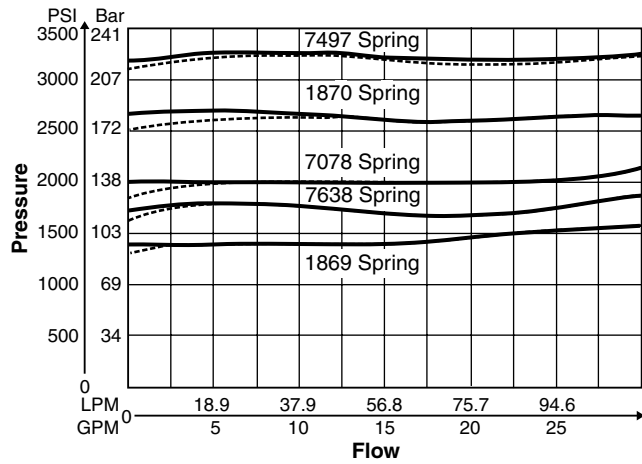

High End – 34 to 207 Bar (500 to 3000 PSI)

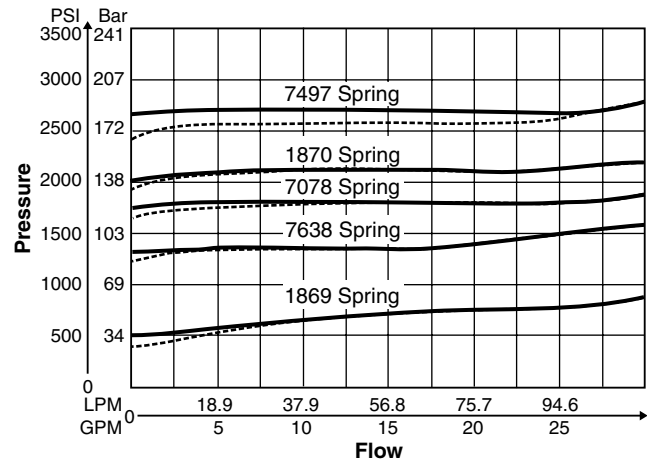

Dimensions

Inch equivalents for millimeter dimensions are shown in (**)

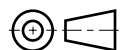
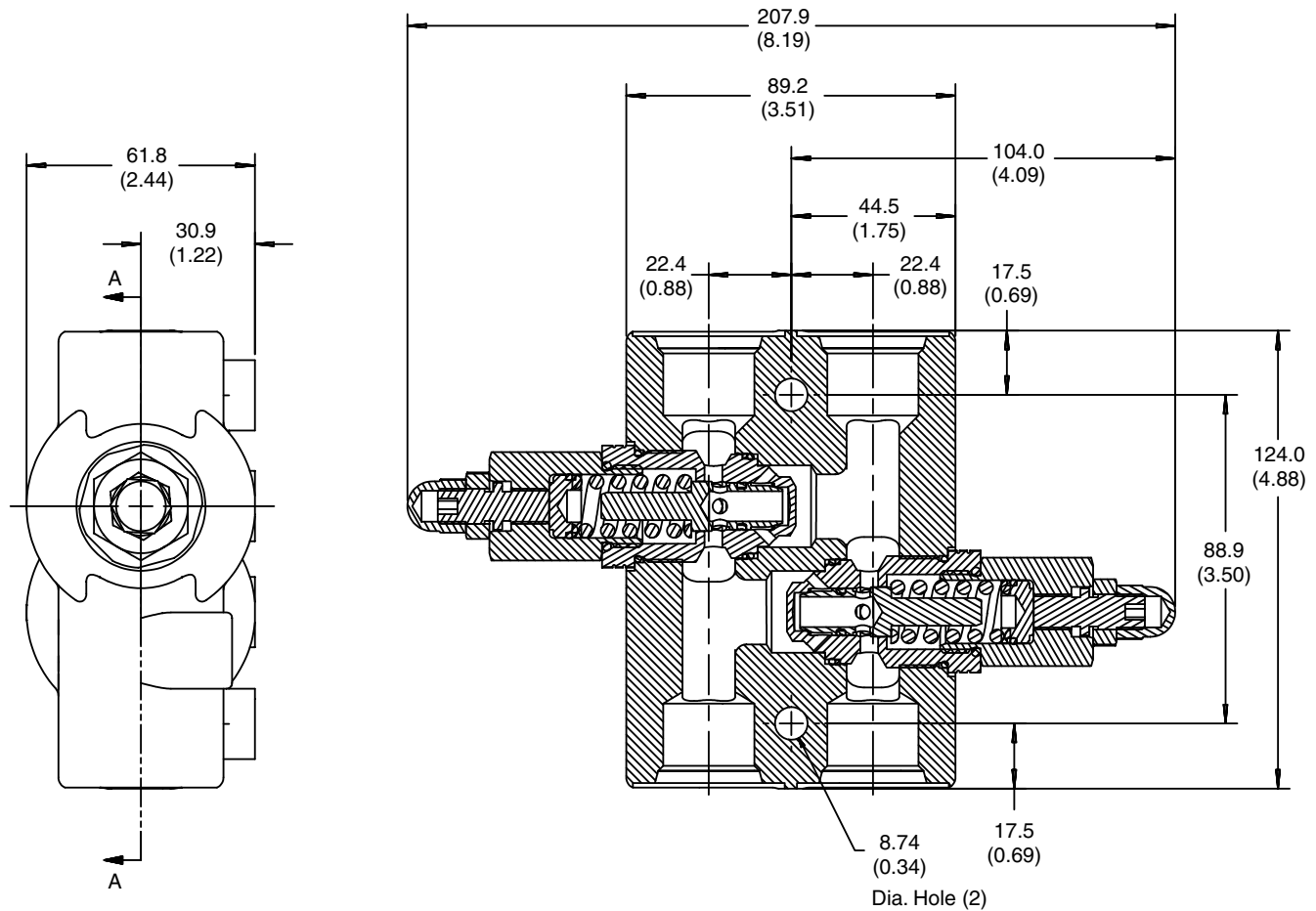

General Description

Series DXV relief valves are direct acting, crossover reliefs (cushion valves). They are designed to eliminate or minimize shock, surge, or overload conditions on hydraulic equipment. They may be used with cylinders of equal displacement, or with motors to provide crossover relief when the motors are stopped.

Operation

The DXV relief valve relieves oil from one side of the actuator to tank, therefore reducing shock and preventing overload. It also eliminates cavitation and the need for a separate tank connection. The valve should be installed as close to the actuator as possible for best results.

Features

- Compact, low profile design
- Hardened seats for long life
- Fast response to cushion shocks and protect actuators
- High tensile, compacted graphite body

Specifications

Input Flow	37.5 LPM (10 GPM)
Operating Pressure SAE Ports NPTF Ports	210 Bar (3000 PSI) 138 Bar (2000 PSI)
Operating Temperature Range (Ambient)	Nitrile Seals: -40°C to +93°C (-40°F to +200°F)
Material	Body – High strength cast iron Poppet – Hardened and ground steel
Filtration	ISO Code 16/13 SAE Class 4 or better
Mounting Position	In-line; no restrictions

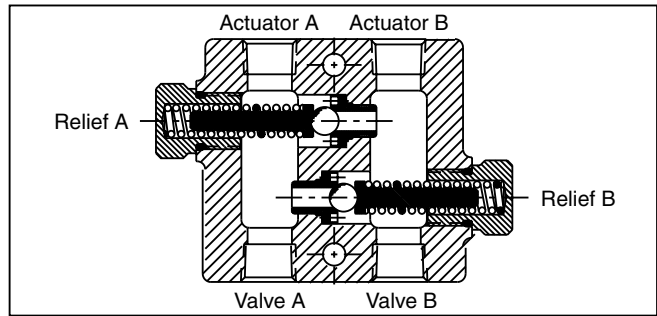
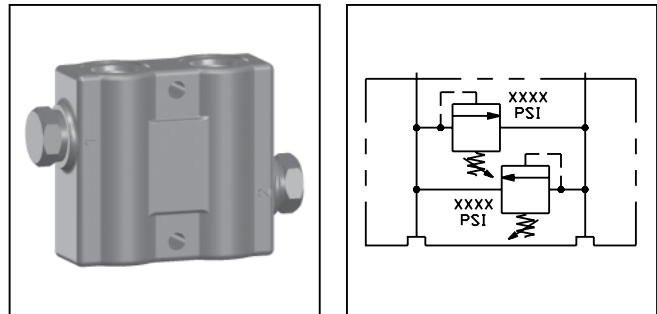

Ordering Information

DXV	—	□	—	□	—	□
Direct Acting Crossover Relief		Port Size		Adjustment Option		Pressure Range

Code	Description
8	SAE-8 (3/4" - 16 UNF)
10	SAE-10 (7/8" - 14 UNF)
38	3/8" - 18 NPT
50	1/2" - 14 NPT
75	3/4" - 14 NPT

Code	Description
Omit	Shim Adjustable

Code	Setting	Range
400	28 Bar (400 PSI)	3.5 - 28 Bar (50 - 400 PSI)
750	53 Bar (750 PSI)	28 - 53 Bar (400 - 750 PSI)
900	64 Bar (900 PSI)	53 - 64 Bar (750 - 900 PSI)
1300	92 Bar (1300 PSI)	64 - 92 Bar (900 - 1300 PSI)
1450	103 Bar (1450 PSI)	91 - 103 Bar (1300 - 1450 PSI)
1800	128 Bar (1800 PSI)	103 - 128 Bar (1450 - 1800 PSI)
2000	142 Bar (2000 PSI)	128 - 142 Bar (1800 - 2000 PSI)
3000*	210 Bar (3000 PSI)	142 - 210 Bar (2000 - 3000 PSI)

* SAE ported bodies only.

Service Parts

Upper Relief Valve Seal	2115N-7
Relief Adjustments Shim Adjustment	
100 PSI	00462001
150 - 250 PSI	00459001
250 - 450 PSI	00458001

Note: The body and the internal parts of the relief valve (including the spring) are non-service items.

Dimensions

Mobile Accessory Valves Series DXV

Inch equivalents for millimeter dimensions are shown in (**)

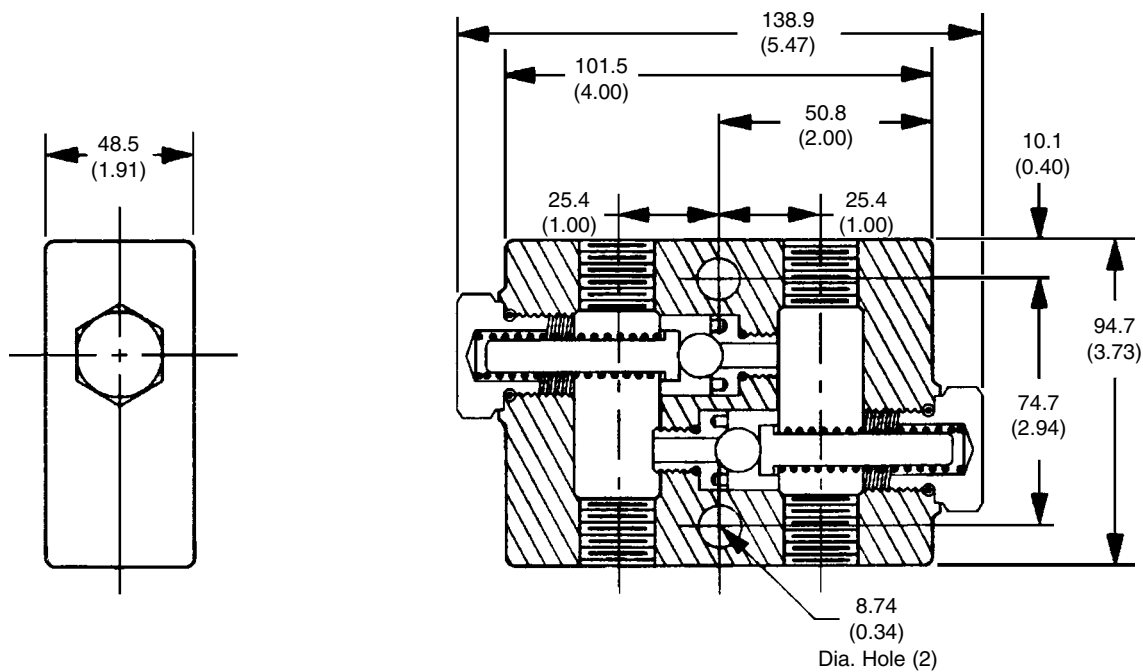

General Description

Series HP50 pilot pressure valves are designed to provide a separately mounted, pilot pressure system for solenoid and hydraulic remote-controlled, directional control valves.

The pilot pressure valve is installed in the hydraulic system between the pump and the directional control valve.

This valve can be used for other applications where a pilot pressure is required. Possible applications are remote-controlled, variable displacement pumps or motors and differential locks.

The valve consists of a mechanical sequence valve and a pressure reducing cartridge. The pilot operated sequence valve creates a stand-by pressure greater than the pressure reducing cartridge. The pressure reducing cartridge limits the maximum pressure in the pilot circuit.

Features

- Eliminates separate pilot pump and relief valve for a pilot system
- Simplifies plumbing for a pilot system
- Easily installed into an existing hydraulic system
- Optional main system relief valve available
- Solenoid kits available

Operation

The mechanical pressure build up valve can be used in open center systems where the pump is not in stand-by operation for long periods of time. Pilot pressure is maintained at all times.

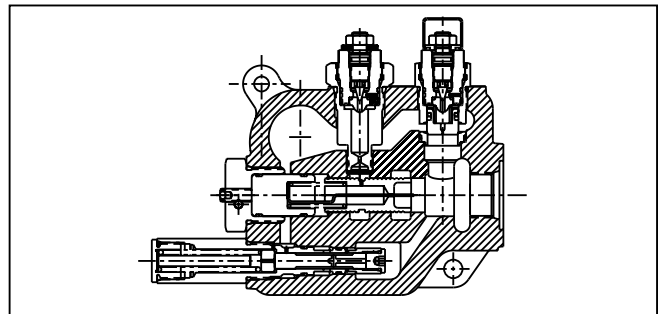
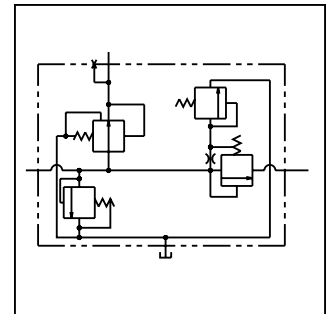
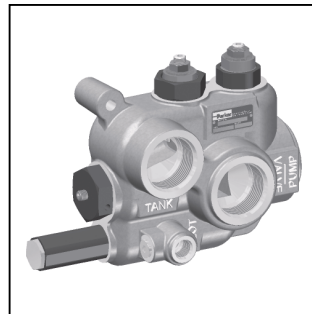
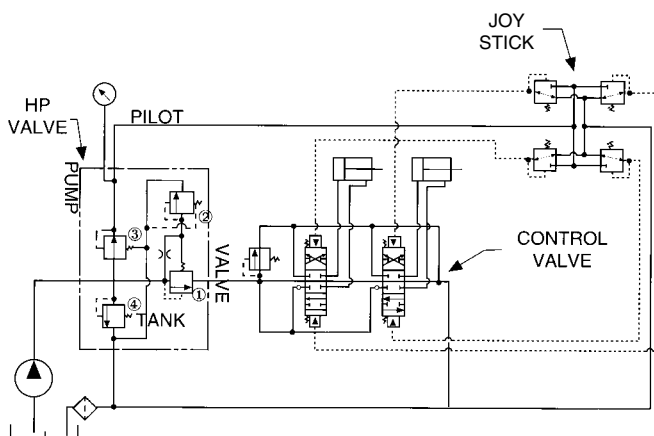

Specifications

Input Flow	187.5 LPM (50 GPM)
Pilot Flow	18.75 LPM (5 GPM)
Operating Pressure Inlet Tank	240 Bar (3500 PSI) 24 Bar (350 PSI)
Operating Temperature Range (Ambient)	Nitrile Seals: -40°C to +93°C (-40°F to +200°F)
Material	Body – High strength cast iron
Filtration	ISO Code 16/13, SAE Class 4 or better
Mounting Position	In-line; no restrictions

Understanding the HP pilot pressure valve

Many open center systems have very little pressure drop through the directional valve when in the neutral position. These systems do not provide enough pressure for pilot operation. To create pilot pressure, use the HP valve.

The HP valve has four basic component parts:

1. Sequence valve slave
2. Sequence valve pilot
3. Reducing valve
4. Relief valve

The sequence slave (part #1) and the sequence pilot (part #2) create the back pressure that is used for pilot operation. The reducing valve (part #3) protects the pilot system from high pressure. The relief valve (part #4) protects the pump. Note that the relief valve is located on the pump side of the sequence valve.

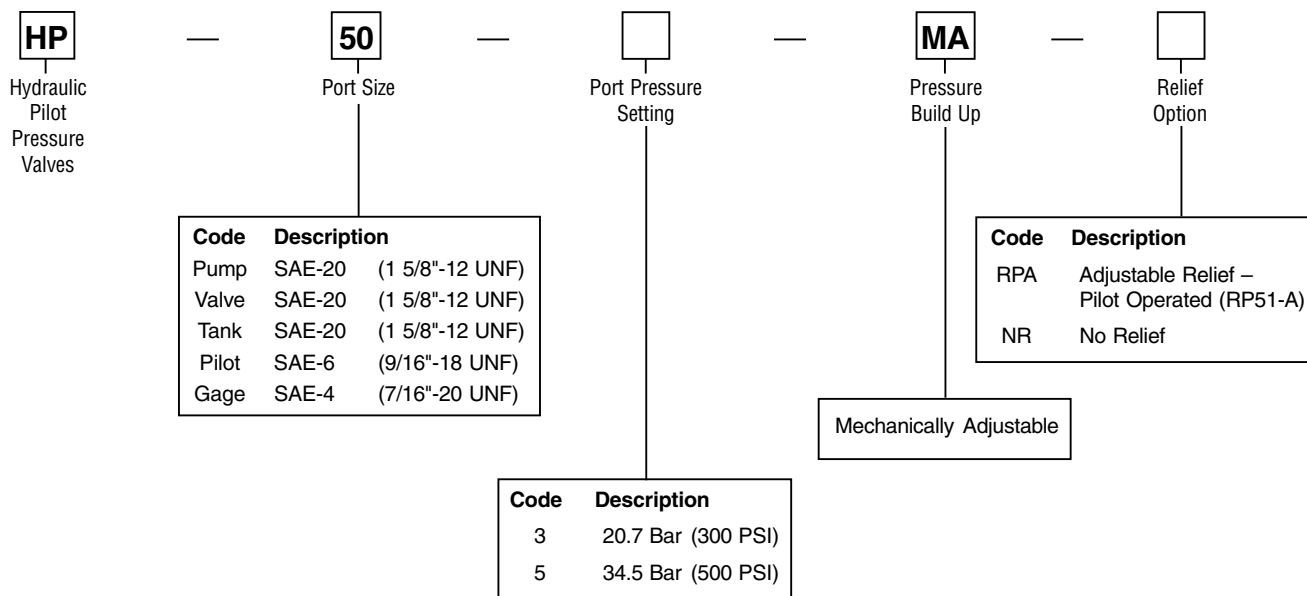

Service Parts

20.7 Bar (300 PSI) Pilot Pressure Reducing Valve	11416001
34.5 Bar (500 PSI) Pilot Pressure Reducing Valve	11416002
NR - no relief plug	04142003
Relief Valve	RP51-A
Pressure Build Up Valve	20275001
Upper Seal - Pressure Build Up Valve	3914V-9
Lower Seal - Pressure Build Up Valve	2019N-7
Lower Back Up Ring - Pressure Build Up Valve	407480
12 VDC Solenoid Unloader Kit	10722001
24 VDC Solenoid Unloader Kit	00711871
Relief Valve Seal Kit	00712223

Note: The body and the internal parts are non-service items.

Dimensions

Inch equivalents for millimeter dimensions are shown in (**)

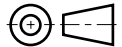
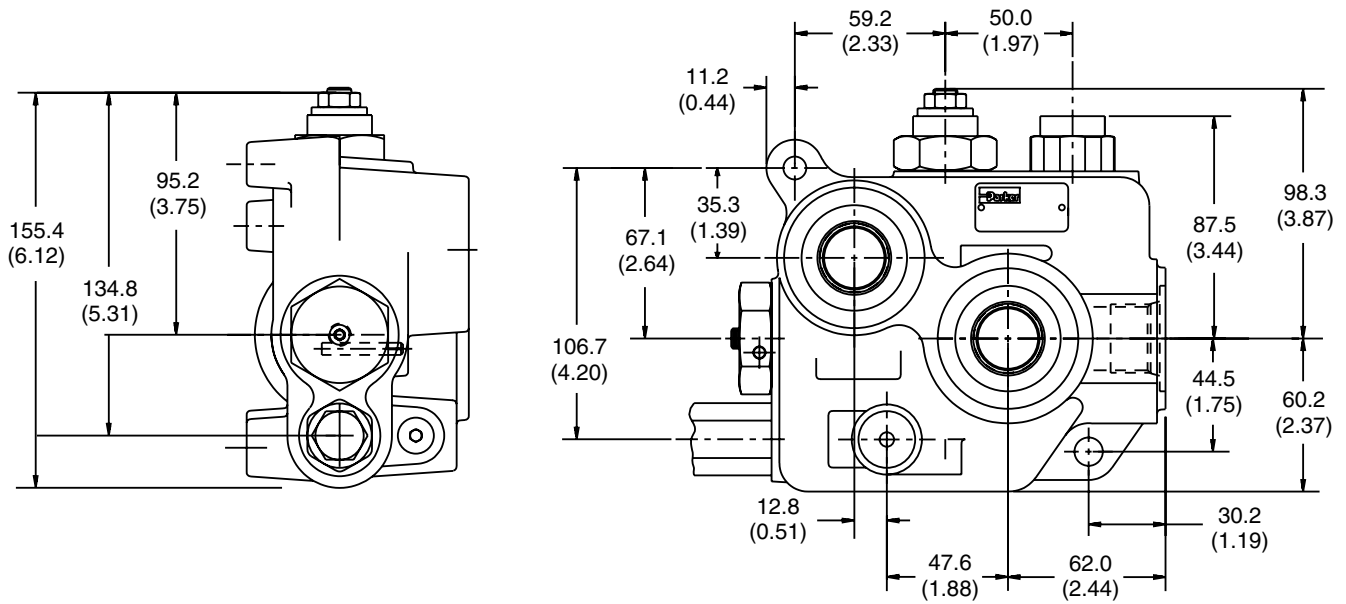

Performance Curve

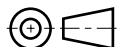
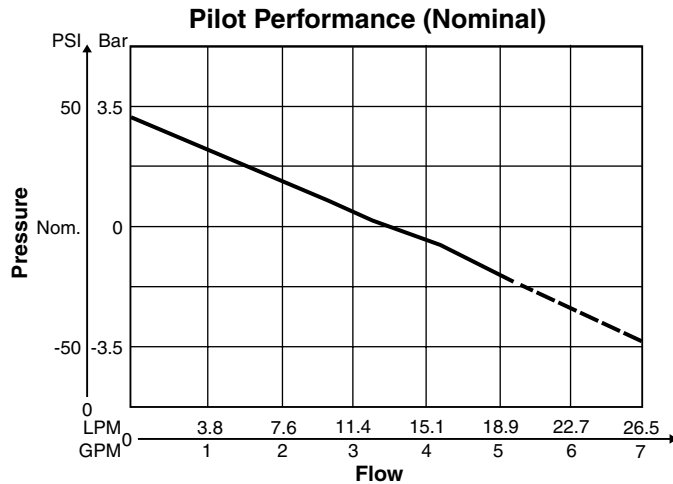

General Description

Series LO valves are single and double, pilot operated check valves. They are designed to lock a cylinder or part of a circuit without leakage, while a control valve is in a neutral position. Lock valves function as check valves, allowing flow to a cylinder and blocking reverse flow until pilot pressure is applied to unlock the circuit. This valve works best when used with a directional control valve that vents the work ports to tank when it is in a neutral mode.

Operation

Free flow is permitted from the valve port to the work port through the check valve. This check prevents reverse flow in the absence of pilot pressure. When adequate pilot pressure is applied at the pilot port, the pilot piston unseats the check poppet permitting free flow.

Features

- Hardened seats
- Ball/Spring check valves
- High tensile, cast iron body

Specifications

Input Flow	93.75 LPM (25 GPM)
Operating Pressure SAE Ports NPTF Ports	210 Bar (3000 PSI) 138 Bar (2000 PSI)
Pilot Ratio	3.36 to 1
Operating Temperature Range (Ambient)	Nitrile Seals: -40°C to +93°C (-40°F to +200°F)
Material	Body – High strength cast iron
Filtration	ISO Code 16/13 SAE Class 4 or better
Mounting Position	In-line; no restrictions

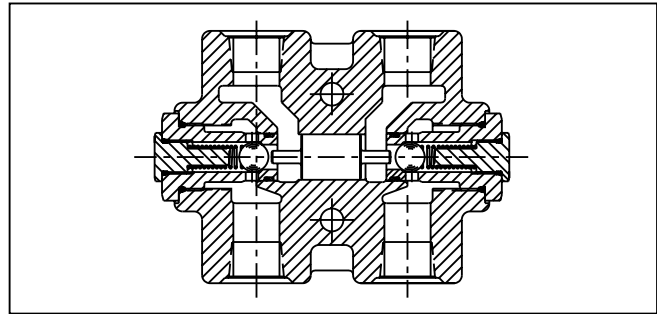
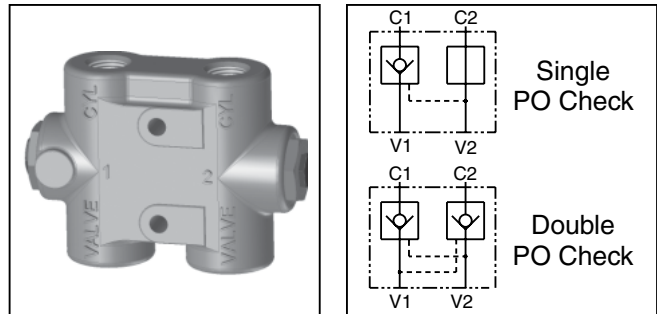

Ordering Information

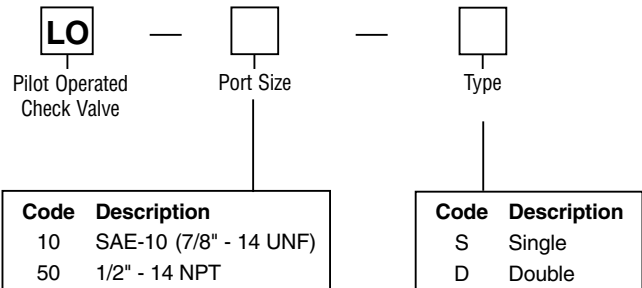

Service Parts

Check Valve	07350001
-------------	----------

Note: The body and the internal parts are non-service items.

Inch equivalents for millimeter dimensions are shown in (**)

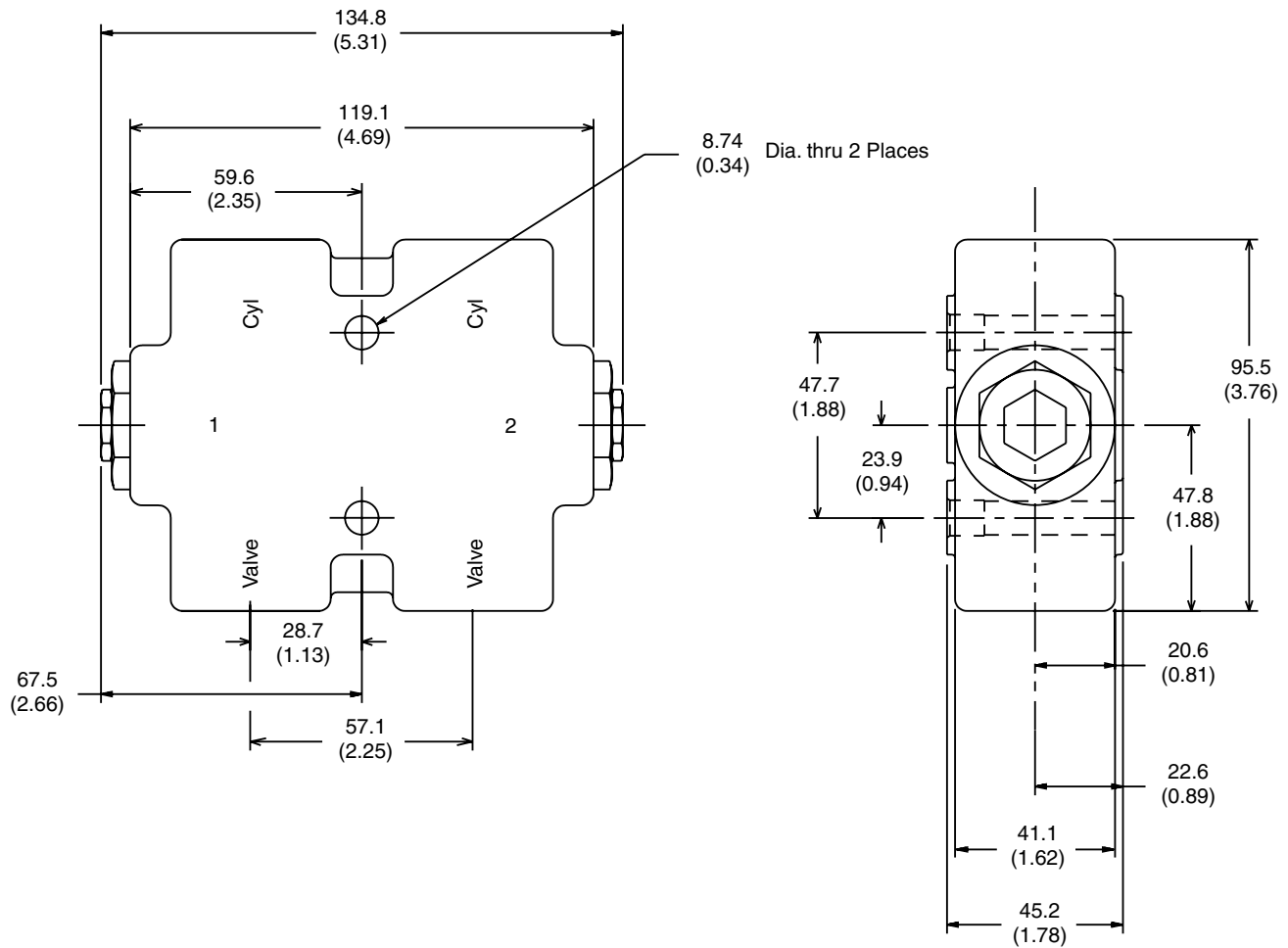

General Description

Series LOA valves are single and double, pilot operated check valves. They are designed to lock a cylinder or part of a circuit without leakage, while a control valve is in a neutral position. Lock valves function as check valves, allowing flow to a cylinder and blocking reverse flow until pilot pressure is applied to unlock the circuit. This valve works best when used with a directional control valve that vents the work ports to tank when it is in a neutral mode.

Operation

Free flow is permitted from the valve port to the work port through the check valve. This check prevents reverse flow in the absence of pilot pressure. When adequate pilot pressure is applied at the pilot port, the pilot piston unseats the check poppet permitting free flow.

Features

- Hardened seats
- Ball/Spring check valves
- High tensile, cast iron body

Specifications

Input Flow	30 LPM (8 GPM)
Operating Pressure SAE Ports NPTF Ports	210 Bar (3000 PSI) 138 Bar (2000 PSI)
Pilot Ratio	3.36 to 1
Operating Temperature Range (Ambient)	Nitrile Seals: -40°C to +93°C (-40°F to +200°F)
Material	Body – High strength cast iron
Filtration	ISO Code 16/13 SAE Class 4 or better
Mounting Position	In-line; no restrictions

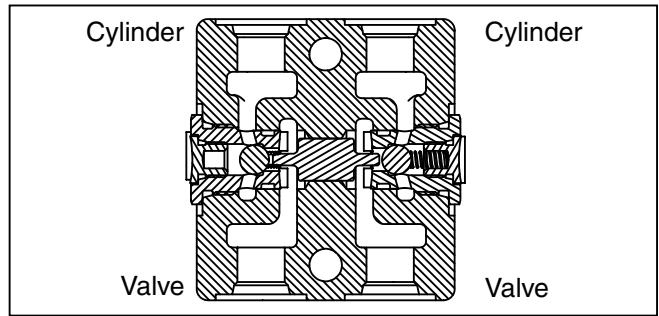
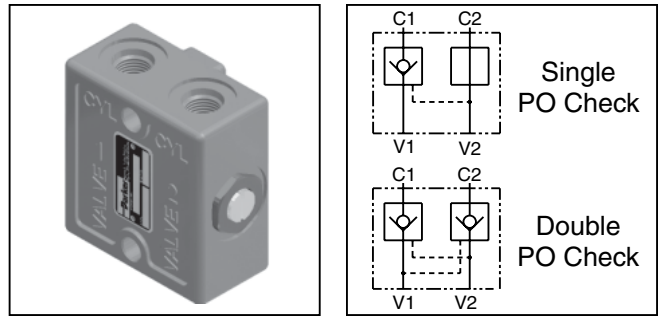

Ordering Information

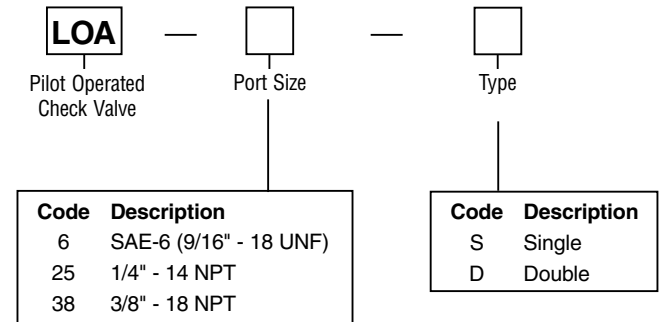

Service Parts

Check Valve	04169001
-------------	----------

Note: The body and the internal parts are non-service items.

Dimensions

Series LOA

Inch equivalents for millimeter dimensions are shown in (**)

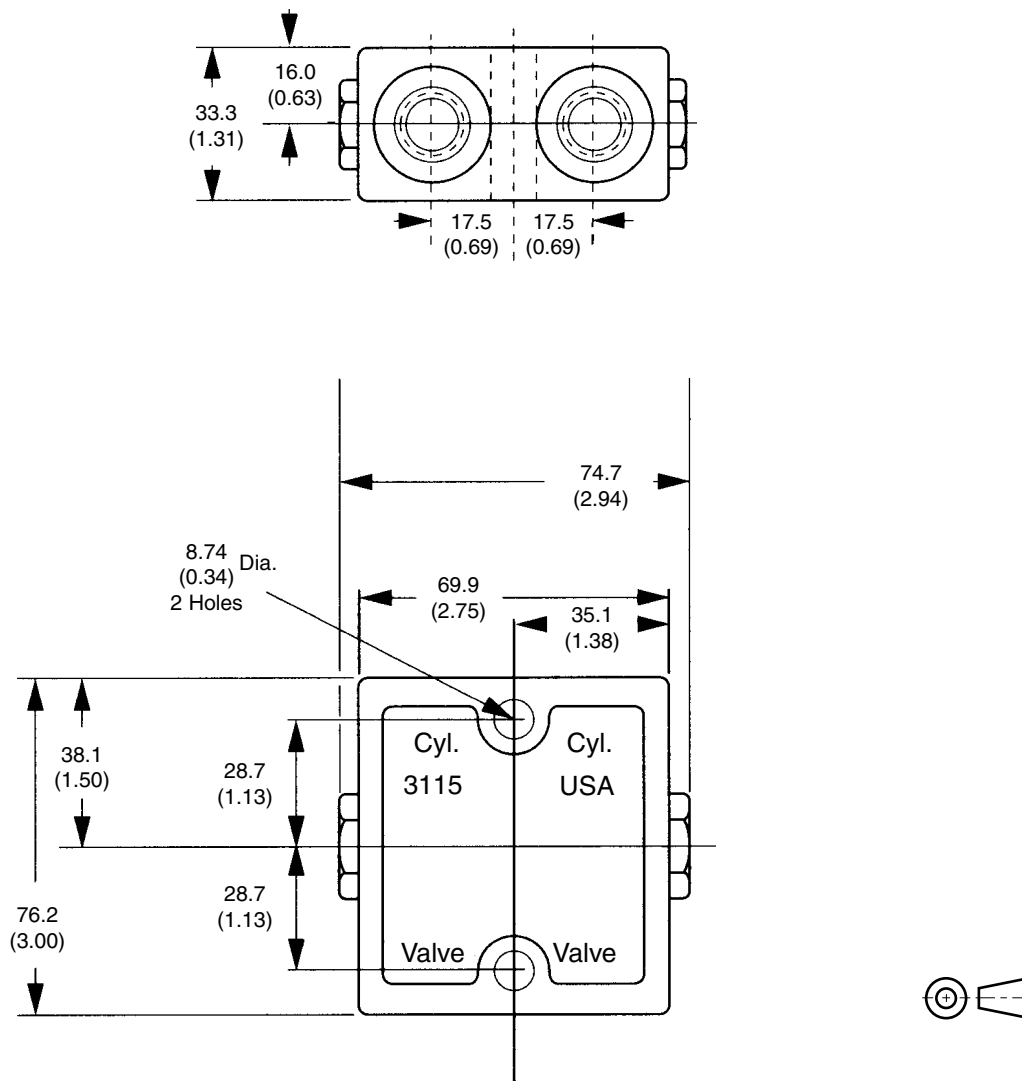

General Description

Series PD and PDC accessory valves are pressure compensated flow dividers. They are designed for applications where two separate hydraulic circuits are to be served from a single pump. The valve splits the flow in three ratios between the two hydraulic lines. Flow through the series PD flow divider cannot be reversed. Flow through the PDC flow divider can be combined in the reverse direction and synchronized in both directions.

Series PD and PDC flow dividers will divide the inlet flow to $\pm 10\%$ of the specified outlet flow when used within recommended capacities. In addition, many actuators can displace fluid different from the ratio of the divider. This can cause two actuators to either lock up or become out of synch. A means of rephasing the actuators is recommended.

Operation

As flow enters the inlet port of the PD version, it will pass through the control orifices in the interconnected spools. The flow passing through the orifices in the spools creates a pressure drop which pulls the two spools away from each other. The flow then passes to the two-divider outlet ports.

When flow is to be combined in the PDC versions, it enters the valve through the two-divider outlet ports. The flow passes through the orifices in the spools creating a pressure drop which pushes the two spools towards each other. The combined flow then passes to the inlet port. The design of the PD spool does not allow flow to combine.

Features

- Pressure compensated
- Cross drilled spool provides accurate metering
- High tensile, cast iron body

Ordering Information

□	—	□	—	□																								
Flow Divider		Port Size		Ratio																								
<table border="1"> <thead> <tr> <th>Code</th> <th>Description</th> </tr> </thead> <tbody> <tr> <td>PD</td> <td>Flow Divider</td> </tr> <tr> <td>PDC</td> <td>Flow Divider/ Combiner</td> </tr> </tbody> </table>	Code	Description	PD	Flow Divider	PDC	Flow Divider/ Combiner		<table border="1"> <thead> <tr> <th>Code</th> <th>Description</th> </tr> </thead> <tbody> <tr> <td>10</td> <td>SAE-10 (3/4" - 16 UNF)</td> </tr> <tr> <td>12</td> <td>SAE 12 (1 1/16" - 12 UNF)</td> </tr> <tr> <td>50</td> <td>1/2" - 14 NPT</td> </tr> <tr> <td>75</td> <td>3/4" - 14 NPT</td> </tr> </tbody> </table>	Code	Description	10	SAE-10 (3/4" - 16 UNF)	12	SAE 12 (1 1/16" - 12 UNF)	50	1/2" - 14 NPT	75	3/4" - 14 NPT		<table border="1"> <thead> <tr> <th>Code</th> <th>Description</th> </tr> </thead> <tbody> <tr> <td>50</td> <td>50/50</td> </tr> <tr> <td>60</td> <td>60/40</td> </tr> <tr> <td>70</td> <td>70/30</td> </tr> </tbody> </table>	Code	Description	50	50/50	60	60/40	70	70/30
Code	Description																											
PD	Flow Divider																											
PDC	Flow Divider/ Combiner																											
Code	Description																											
10	SAE-10 (3/4" - 16 UNF)																											
12	SAE 12 (1 1/16" - 12 UNF)																											
50	1/2" - 14 NPT																											
75	3/4" - 14 NPT																											
Code	Description																											
50	50/50																											
60	60/40																											
70	70/30																											

NPT pipe ports are not recommended for pressures above 138 Bar (2000 PSI)

Note: The PDC is only available in a 50/50 ratio.

Service Parts

Spool Seal	3914N-9 (2 required)
------------	----------------------

Note: The body and the internal parts are non-service items.

PD-PDC.p65, dd

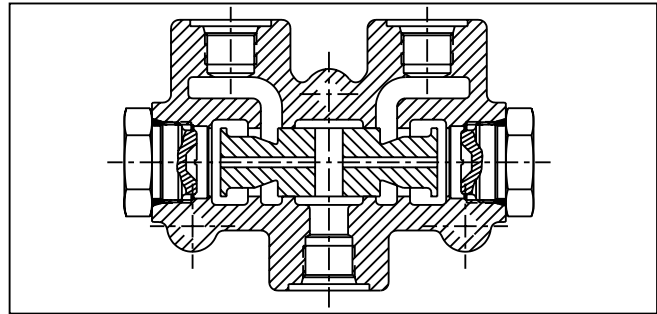
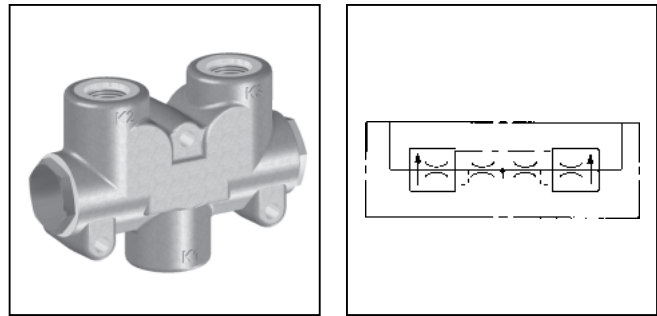

Specifications

Input Flow PD / PDC50 PD / PDC75 PD / PDC12	18.75 - 75 LPM (5 - 20 GPM) 75 - 131.25 LPM (20 - 35 GPM) 75 - 131.25 LPM (20 - 35 GPM)
Accuracy	$\pm 10\%$
Operating Pressure SAE Ports NPTF Ports	177 Bar (2500 PSI) 138 Bar (2000 PSI)
Operating Temperature Range (Ambient)	Nitrile Seals: -40°C to +93°C (-40°F to +200°F)
Material	Body – High strength cast iron Spool – Hardened and ground steel
Filtration	ISO Code 16/13 SAE Class 4 or better
Mounting Position	In-line; no restrictions

Performance Curves

In Divider Mode from Inlet to Joined Legs

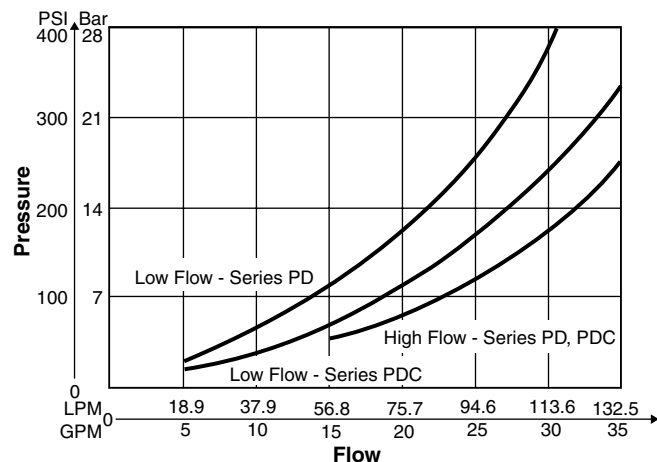

Inch equivalents for millimeter dimensions are shown in (**)

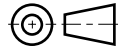

Series PD

Standard Flow Divider

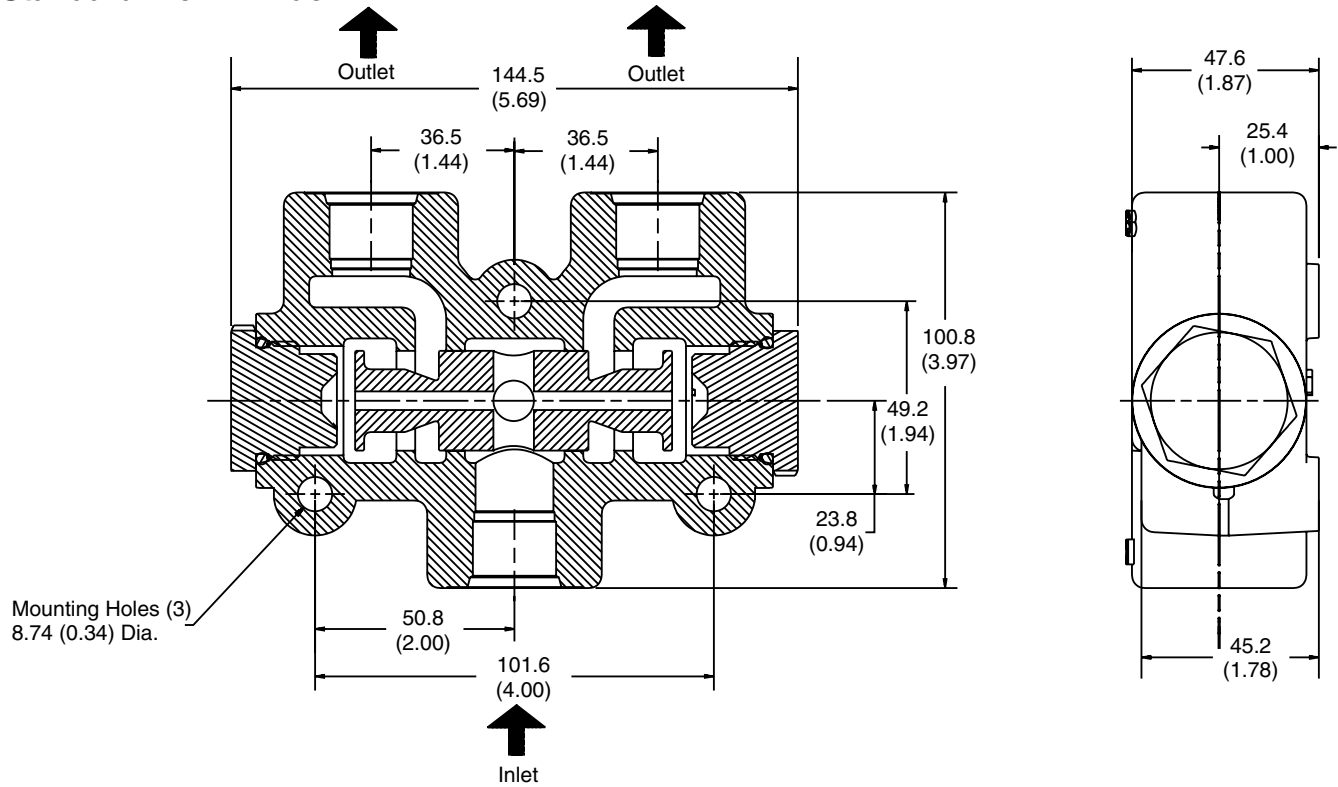

Series PDC

Flow Divider / Combiner

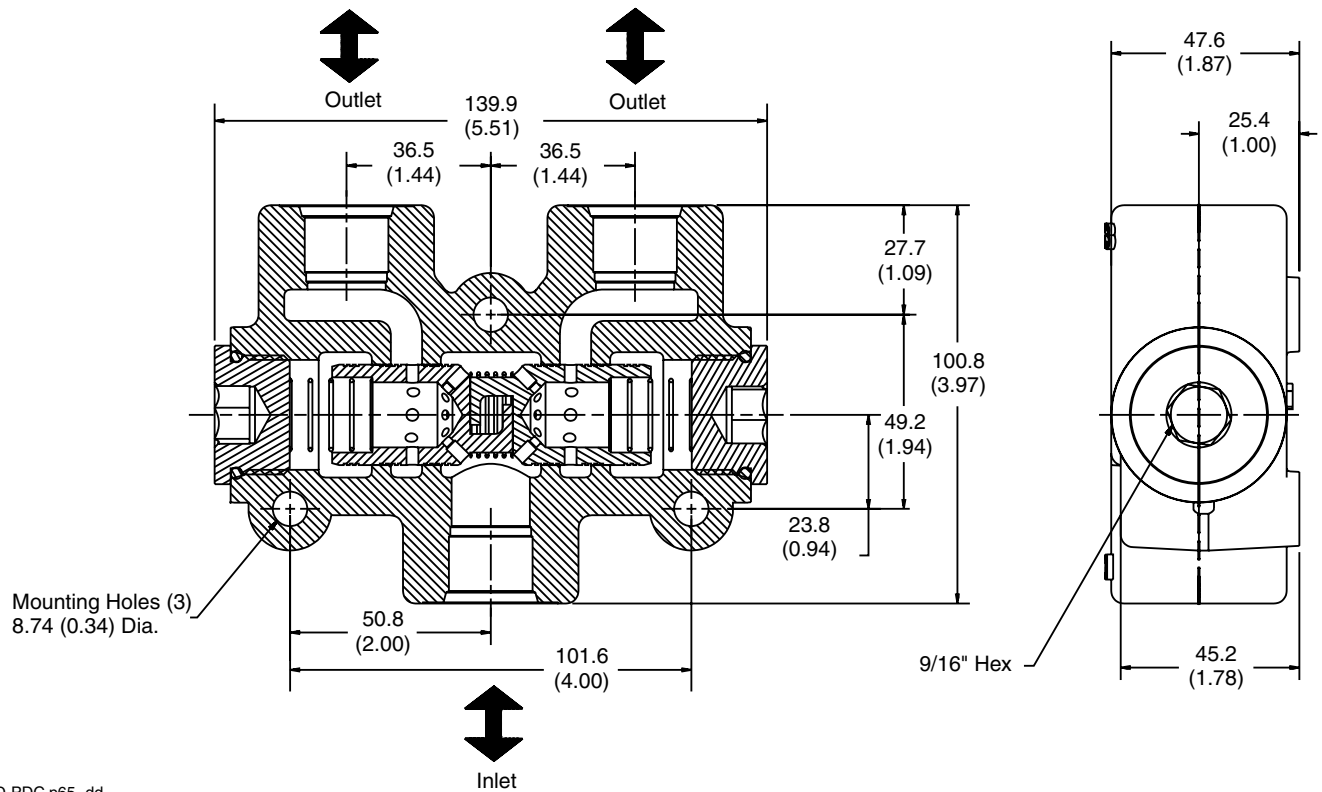

General Description

Series RPJL accessory valves are relief valves used for limiting the maximum pressure which can be applied to the portion of the hydraulic circuit where it is connected.

Series RPJL relief valves are pilot operated, poppet-type relief valves. Their best application is a main system relief where smooth consistent performance is required.

Operation

The pilot section opens when inlet pressure on the RPJL relief valve exceeds the valve setting. This pilot flow creates a pressure imbalance across the main section causing the valve to open. The pilot section closes once the inlet pressure drops below the valve setting. This then re-seats the poppet in the main valve and closes it.

Features

- Compact, low profile design
- Hardened and ground poppet
- High tensile, compacted graphite body

Ordering Information

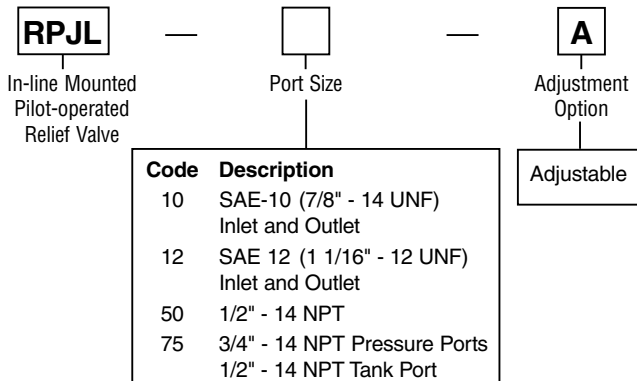

Note: NPT pipe ports are not recommended for pressures above 138 Bar (2000 PSI)

A right angle flow (former T option) is created by plugging one of the P ports.

Service Parts

Relief Valve	RP51-A-5000
O-Ring Seal Kit	00712223
Body Kit	
RPJL-10	K-WJL-10
RPJL-50	K-WJL-50
RPJL-75	K-WJL-75
Relief Adjustment	
1/4 turn = 200 PSI ±10%	

Note: The internal parts of the relief valve (including the spring) are non-service items.

RPJL.p65, dd

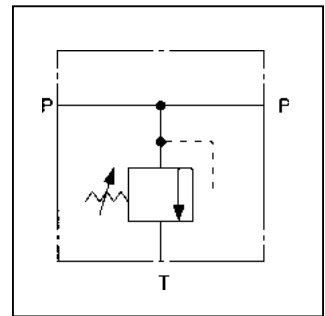
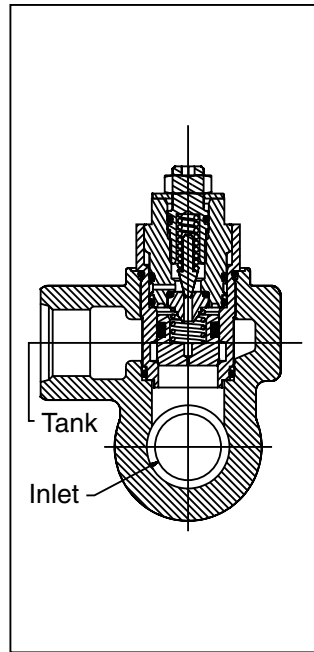

Specifications

Input Flow	93.75 LPM (25 GPM)
Operating Pressure SAE Ports NPTF Ports	350 Bar (5000 PSI) 138 Bar (2000 PSI)
Operating Temperature Range (Ambient)	Nitrile Seals: -40°C to +93°C (-40°F to +200°F)
Material	Body – High strength cast iron Spool – Hardened and ground steel
Filtration	ISO Code 16/13 SAE Class 4 or better
Mounting Position	In-line; no restrictions

Performance Curve

Crack – 34 to 345 Bar (500 to 5000 PSI)

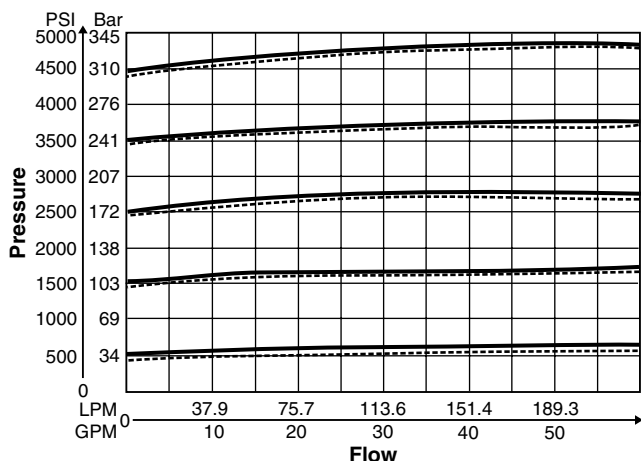

Dimensions

**Mobile Accessory Valves
Series RPJL**

Inch equivalents for millimeter dimensions are shown in (**)

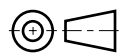
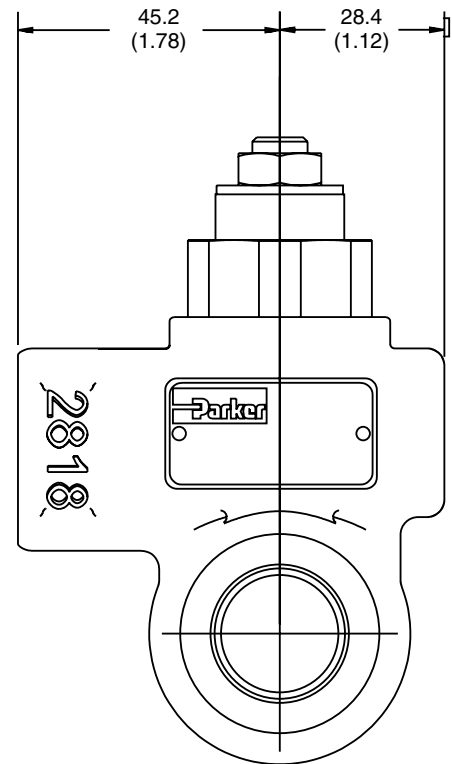
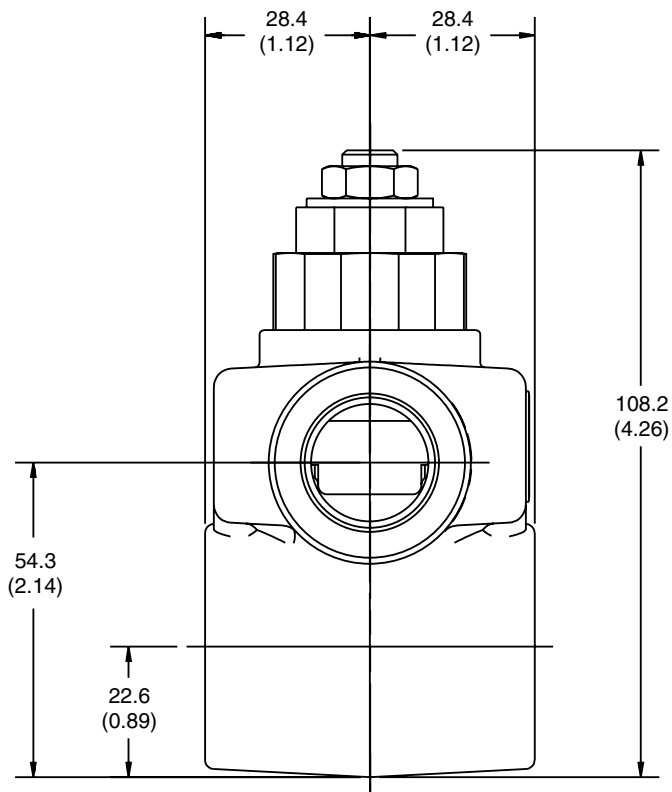

General Description

Series RPL relief valves are pilot operated, ball-type relief valves. Their best application is a main system relief where smooth consistent performance is required.

Operation

The pilot section opens when inlet pressure on the RPL relief valve exceeds the valve setting. This pilot flow creates a pressure imbalance across the main section causing the valve to open. The pilot section closes once the inlet pressure drops below the valve setting. As a result, this re-seats the poppet in the main valve and closes it.

Features

- Compact, low profile design
- Pilot operated for smooth, stable operation
- High tensile, compacted graphite body

Specifications

Input Flow	225 LPM (60 GPM)
Operating Pressure SAE Ports NPTF Ports	350 Bar (5000 PSI) 138 Bar (2000 PSI)
Operating Temperature Range (Ambient)	Nitrile Seals: -40°C to +93°C (-40°F to +200°F)
Material	Body – High strength cast iron Poppet – Hardened and ground steel
Filtration	ISO Code 16/13 SAE Class 4 or better
Mounting Position	In-line; no restrictions

Ordering Information

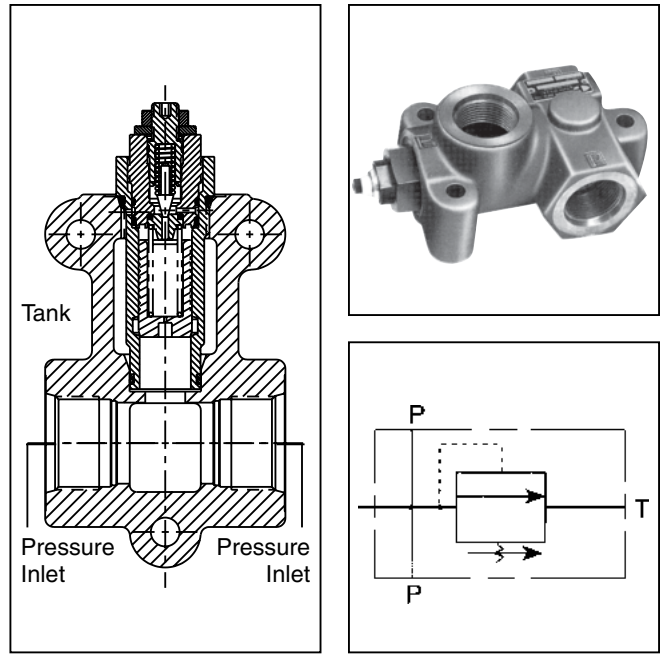
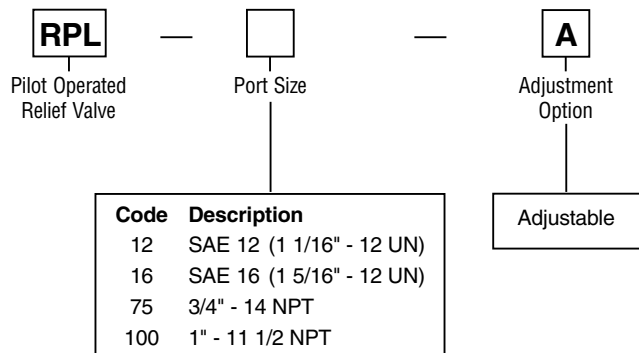

Performance Curve

Crack – 34 to 345 Bar (500 to 5000 PSI)

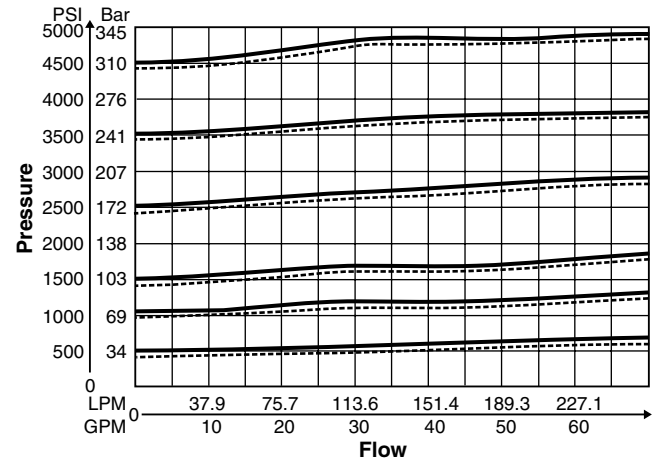

Service Parts

Relief Valve	RP60-A
External Seal – relief valve	3914N-9
Body Kit	
RPL-16	K-RPL-16
RPL-75	K-RPL-75
RPL-100	K-RPL-100
Relief Adjustment	1/4 turn = 200 PSI ±10%

Note: The body and the internal parts of the relief valve (including the spring) are non-service items

Inch equivalents for millimeter dimensions are shown in (**)

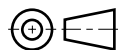
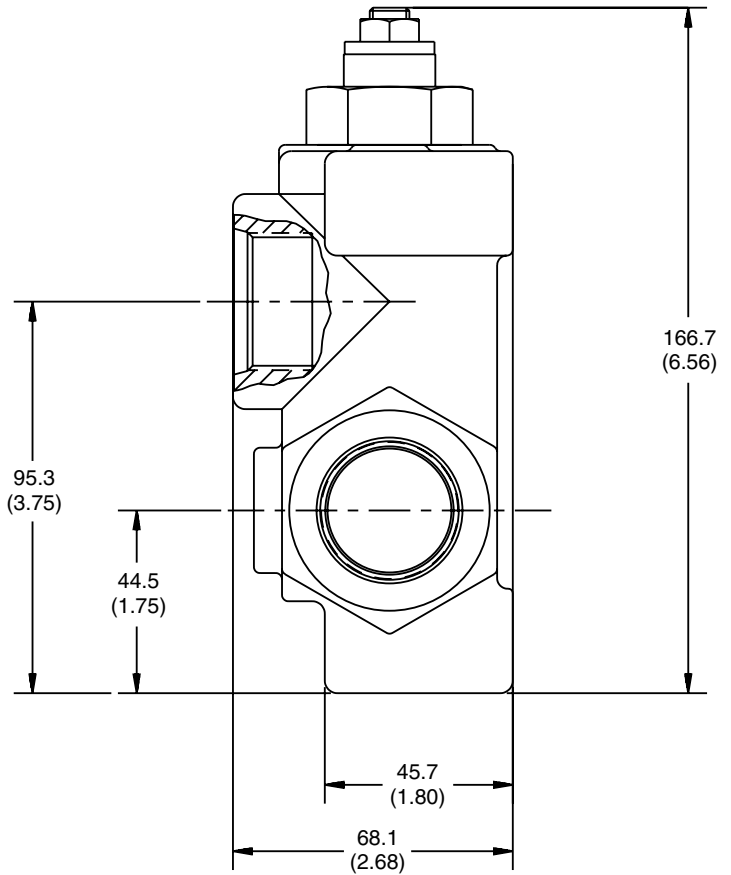
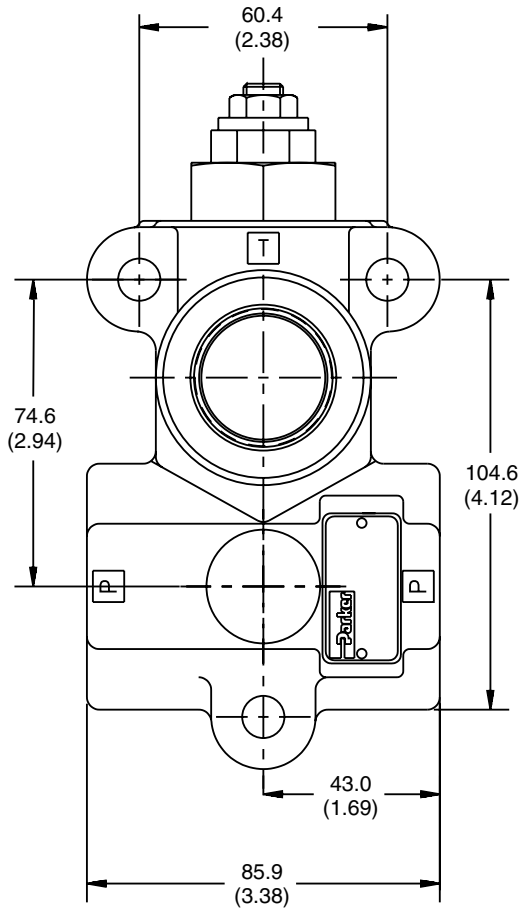

General Description

Series S and SM accessory valves are two-position, three way selector valves. They are designed for directing flow from one single pump to one, or the other of two separate hydraulic lines. An example of this is the operation of two single-acting cylinders, independent of each other.

Series H and HM accessory valves are two-position, three way selector valves. They are designed to be used with a three-position, four way valve to provide a float or free-wheeling condition. Application examples include plows, loaders, and certain winches.

All four versions of this valve should be shifted prior to the application of pressure. The flow forces might make this valve difficult to shift under normal operating pressure and flow conditions.

Operation

Flow enters the valve at the inlet port. When the lever is pushed in, the spool shifts allowing inlet flow to reach the work port furthest away from the lever. When the lever is pulled out, the spool shifts allowing inlet flow to reach the work port closest to the lever.

Features

- Pressure balanced spool
- Chrome plated spool
- High-tensile cast iron body

Specifications

Input Flow 37.5 LPM (10 GPM) 75 LPM (20 GPM) 112.5 LPM (30 GPM) 225 LPM (60 GPM)	HM-8 and HM-50	Operating Temperature Range (Ambient) Nitrile Seals: -40°C to +93°C (-40°F to +200°F)
	S-8, SM-8, S-10, S-50 and SM-50	
Operating Pressure SAE Ports NPTF Ports	207 Bar (3000 PSI)	Material Body – High strength cast iron Spool – Hardened and ground steel
	138 Bar (2000 PSI)	
	Filtration ISO Code 16/13 SAE Class 4 or better	Mounting Position In-line; no restrictions
	Material Body – High strength cast iron Spool – Hardened and ground steel	

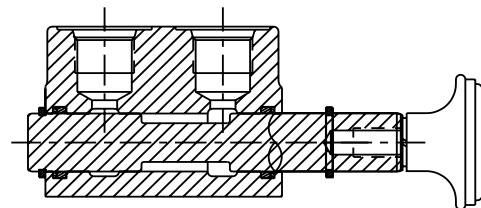
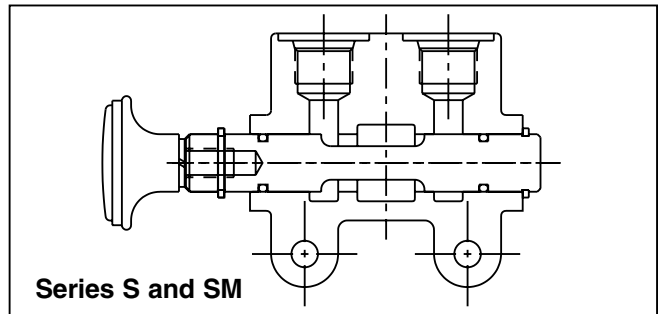
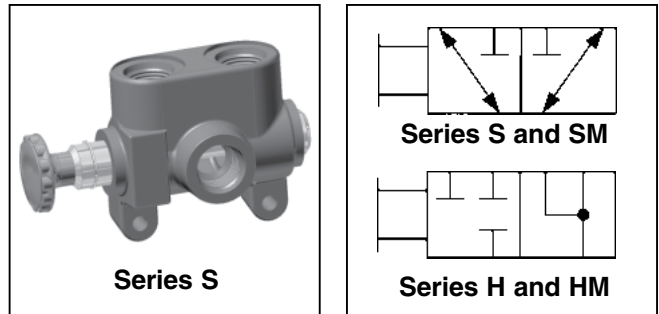

□	Series
Code	Description
S	Circuit Selector
SM	Circuit Selector
H	Float Selector
HM	Float Selector

□	Port Size
Code	Description
8	SAE 8 (3/4" - 16 UNF)
10	SAE 10 (7/8" - 14 UNF)
12	SAE 12 (1 1/16" - 12 UN)
50	1/2" - 14 NPT
75	3/4" - 14 NPT
100	1" - 11 1/2 NPT

The following models are not available:

H-8	HM-10	SM-10
H-10	HM-12	SM-12
H-16	HM-16	SM-16
H-50	HM-75	SM-75
H-100	HM-100	SM-100

All valves are shipped with a knob.

Service Parts

Knob Kit with Lockwasher all versions	06645001
Clevis Kit	08650235
Spool Seal & Retaining Ring Kit Size 12 and 75 only (H or S)	06492001
Size 8, 10 and 50 only (H or S)	06490001
Size 16 and 100 only (H or S)	06493001
Spool Seal, Retaining Ring & Back-up Ring Kit (HM & SM Only)	11411001

Note: The body and the spool are not service items.

Dimensions

**Mobile Accessory Valves
Series S and H**

Inch equivalents for millimeter dimensions are shown in (**)

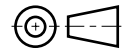
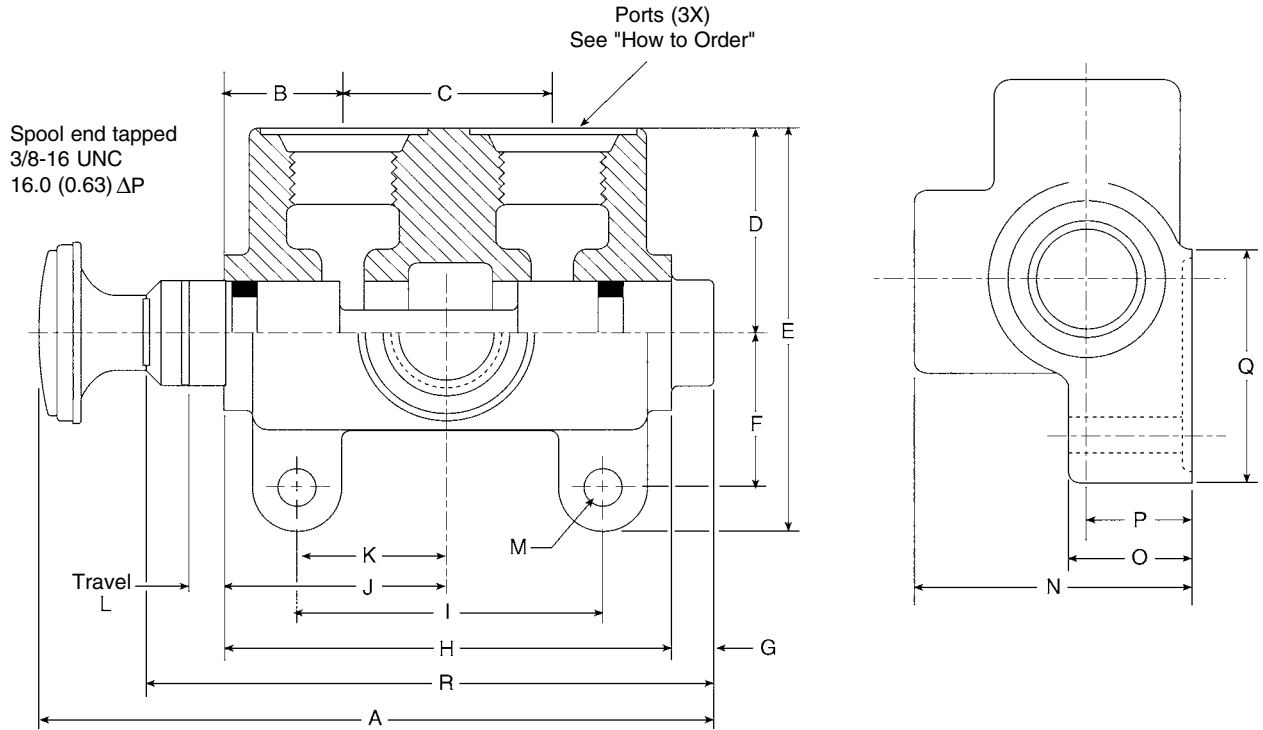

Series	A	B	C	D	E	F	G	H	I	J	K	L	M	N	O	P	Q	R
S-50	147.1 (5.79)	24.6 (0.97)	41.4 (1.63)	42.9 (1.69)	84.1 (3.31)	30.2 (1.19)	6.4 (0.25)	90.4 (3.56)	54.1 (2.13)	45.2 (1.78)	26.9 (1.06)	7.9 (0.31)	8.9 (0.35)	66.6 (2.62)	28.5 (1.12)	25.4 (1.00)	50.8 (2.00)	117.4 (4.62)
S-75	168.2 (6.62)	28.7 (1.13)	53.9 (2.12)	52.3 (2.06)	101.6 (4.00)	38.1 (1.50)	6.4 (0.25)	111.3 (4.38)	76.2 (3.00)	55.6 (2.19)	38.1 (1.50)	9.7 (0.38)	8.9 (0.35)	66.6 (2.62)	28.5 (1.12)	25.4 (1.00)	58.7 (2.31)	138.2 (5.44)
S-100	188.5 (7.42)	30.2 (1.19)	65.0 (2.56)	57.2 (2.25)	114.3 (4.50)	42.9 (1.69)	6.4 (0.25)	125.5 (4.94)	87.4 (3.44)	62.7 (2.47)	43.7 (1.72)	9.7 (0.38)	10.4 (0.41)	88.9 (3.50)	35.1 (1.38)	31.8 (1.25)	73.2 (2.88)	158.8 (6.25)
H-75	168.2 (6.62)	28.7 (1.13)	53.9 (2.12)	52.3 (2.06)	101.6 (4.00)	38.1 (1.50)	6.4 (0.25)	111.3 (4.38)	76.2 (3.00)	55.8 (2.19)	38.1 (1.50)	9.7 (0.38)	8.9 (0.35)	66.6 (2.62)	28.5 (1.12)	25.4 (1.00)	58.7 (2.31)	138.2 (5.44)

Dimensions

**Mobile Accessory Valves
Series SM and HM**

Inch equivalents for millimeter dimensions are shown in (**)

Series SM and HM share a common housing, but have dissimilar spools. Common dimensions are depicted while differences are charted.

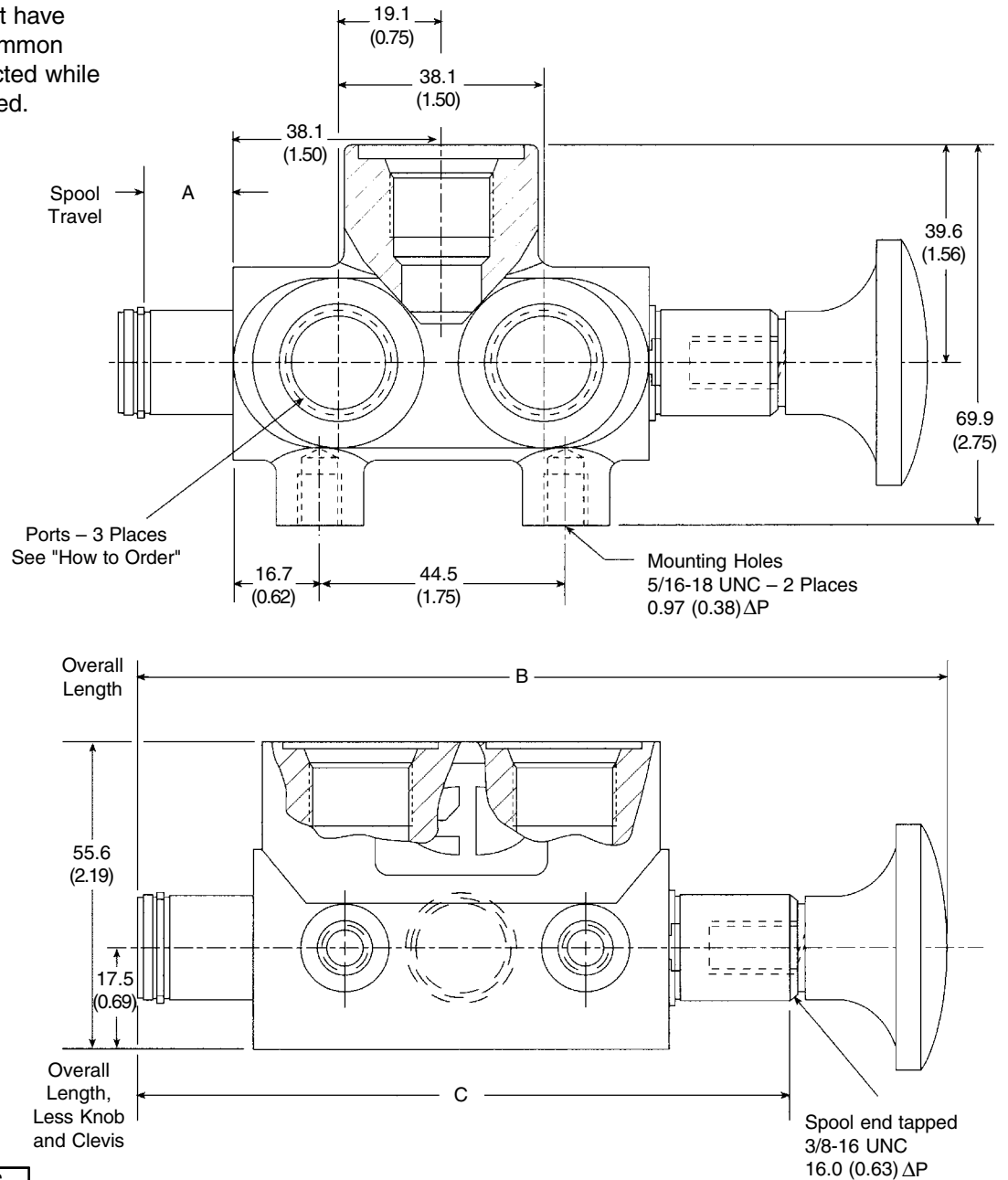

Series	A	B	C
SM	16.0 (0.63)	150.4 (5.92)	120.7 (4.75)
HM	10.4 (0.40)	140.7 (5.54)	111.3 (4.38)

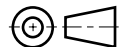

Series S

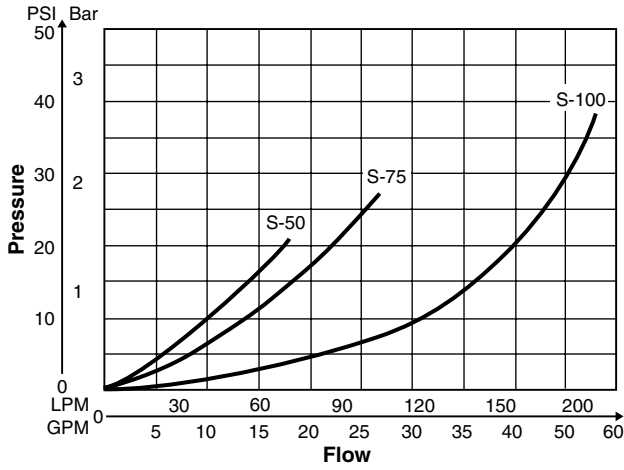

Note: Model S selectors will tolerate flow rates well in excess of those shown here. Consideration should be given to the restrictiveness of the port adaptors.

Series SM

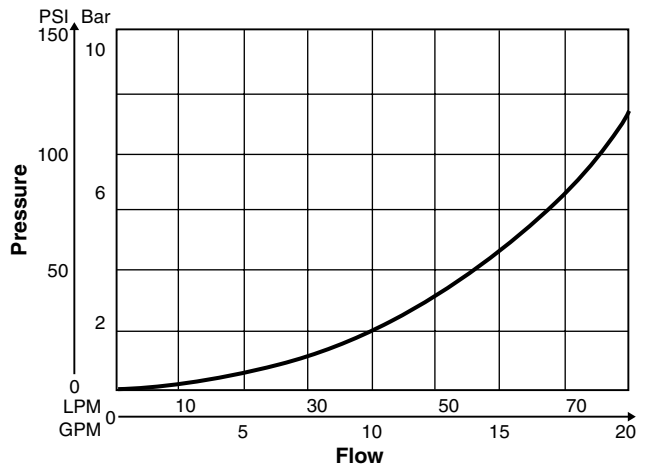

Series H

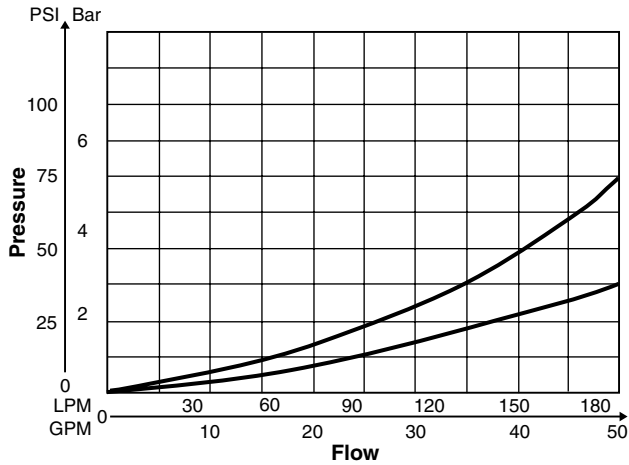

Series HM

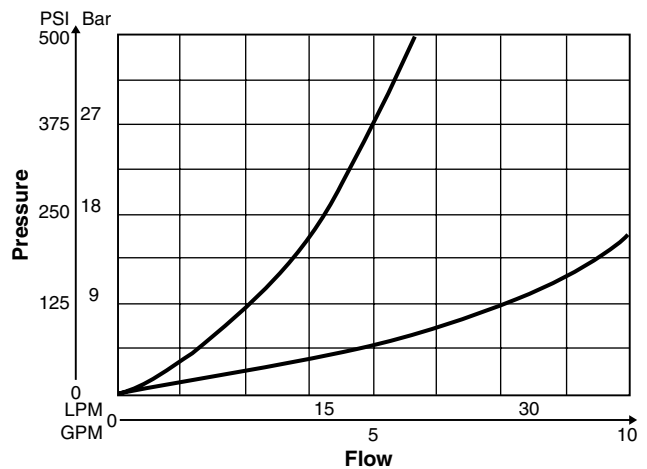

General Description

Series WJL accessory valves are relief valves used for limiting the maximum pressure which can be applied to the portion of the hydraulic circuit where it is connected.

Series WJL relief valves are differential poppet-type relief valves. Their best application is a cylinder port relief where fast response time is required.

Operation

Pressure on the inlet of the WJL relief valve acts on the differential area of the poppet (area difference between the O.D. of the poppet and the seat diameter) to produce a force which is opposed by the spring force. The poppet is pushed off its seat when pressure reaches the valve setting. The spring force re-seats the poppet once the pressure drops below the valve setting.

Features

- Compact, low profile design
- Hardened and ground poppet
- High tensile, compacted graphite body

Specifications

Input Flow	93.75 LPM (25 GPM)
Operating Pressure SAE Ports NPTF Ports	210 Bar (3000 PSI) 138 Bar (2000 PSI)
Operating Temperature Range (Ambient)	Nitrile Seals: -40°C to +93°C (-40°F to +200°F)
Material	Body – High strength cast iron Spool – Hardened and ground steel
Filtration	ISO Code 16/13 SAE Class 4 or better
Mounting Position	In-line; no restrictions

Note: A right angle flow path (former T option) is created by plugging one of the P ports.

Service Parts

Relief Valve Cartridges 35 - 89 Bar (500 - 1250 PSI) 89 - 142 Bar (1250 - 2000 PSI) 142 - 177 Bar (2000 - 2500 PSI) 177 - 210 Bar (2500 - 3000 PSI)	WHA-1250 WHA-2000 WHA-2500 WHA-3000	Body Kits WJL-10 WJL-50 WJL-75	K-WJL-10 K-WJL-50 K-WJL-75
O-Ring Seal Kit	00712223	Relief Adjustments Screw Adjustment – 1/4 turn = 200 PSI ±10% Shim Adjustment – 100 PSI 150 - 250 PSI 250 - 450 PSI	00462001 00459001 00458001

Note: The internal parts of the relief valve (including the spring) are non-service items.

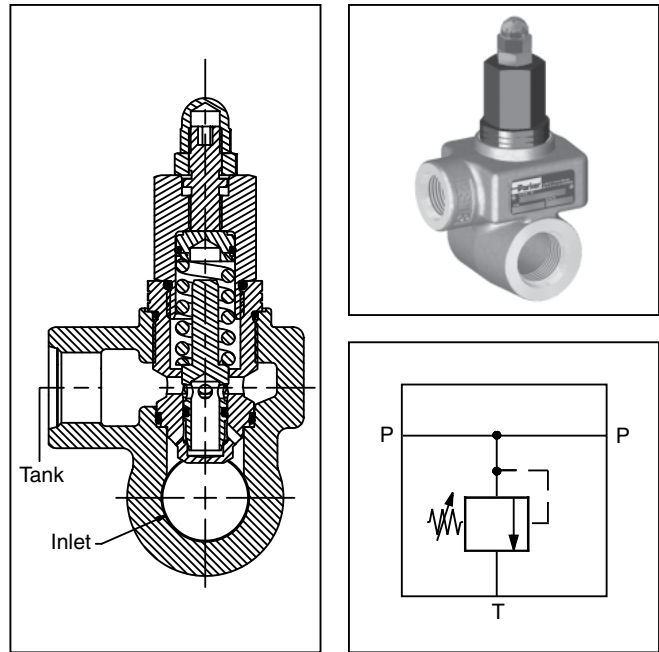

Ordering Information

WJL — — — —

In-line Mounted WH Differential Poppet Relief Valve Port Size Adjustment Option Pressure Range

Code	Description	Code	Description
10	SAE-10 (7/8" - 14 UNF)	Omit	Shim Adjustable
12	SAE 12 (1 1/16" - 12 UNF)	A	Screw Adjustable
50	1/2" - 14 NPT		
75	3/4" - 14 NPT Pressure Ports 12" - 14 NPT Tank Port		

Note: NPT pipe ports are not recommended for pressures above 138 Bar (2000 PSI)

Code	Setting	Range
1250	89 Bar (1250 PSI)	35 - 89 Bar (500 - 1250 PSI)
2000	142 Bar (2000 PSI)	89 - 142 Bar (1250 - 2000 PSI)
2500	177 Bar (2500 PSI)	142 - 177 Bar (2000 - 2500 PSI)
3000	210 Bar (3000 PSI)	142 - 210 Bar (2000 - 3000 PSI)

Performance Curves

Low End – 34 to 207 Bar (500 to 3000 PSI)

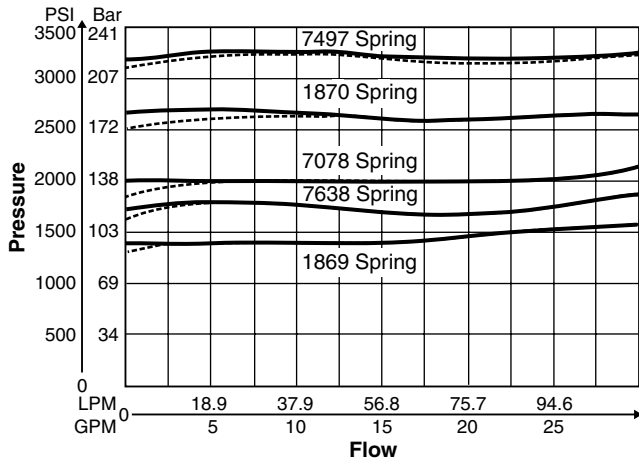

High End – 34 to 207 Bar (500 to 3000 PSI)

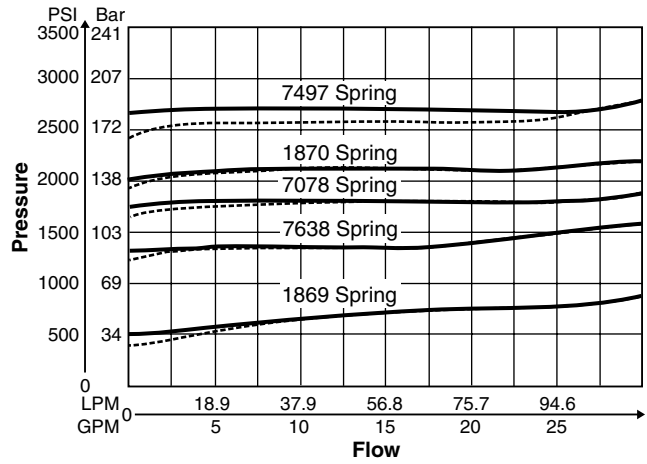

Dimensions

Inch equivalents for millimeter dimensions are shown in (**)

